



PRODUCT SPECIFICATION

KADI Model: KD080QXG04EA-DC26

CUSTOMER Model: -

Description: 8.0 " TFT-LCD Module with CTP

Version: 2.0

KADI	PREPARED BY	CHECKED BY	APPROVED BY
SIGNATURE			
DATE	2023.11.13	2023.11.13	2023.11.13

CUSTOMER APPROVAL	SIGNATURE	DATE



Contents

1. General Specifications	4
2. Absolute Maximum Ratings	5
3. Electrical Characteristics	5
4. Interface Pin Assignment	7
5. Interface Characteristics	9
6. Optical Specifications	14
7. Reliability Test Items	18
8. Mechanical Drawing	19
9. Packing	20
10. Precautions for Use of LCD modules	21



1. General Specifications

1.1 LCM General Information

Item	Specification	Unit
LCD Size	8.0	inch
Number of Pixels	1024 (H) RGB x 768 (V)	pixels
Display Mode	Normally Black	-
Viewing Direction	Free	o' clock
Interface	LVDS	-
Display Colors	16.7M	colors
Outline Dimension	183 (H) x 141 (V) x 8.27 (D)	mm
Active Area	162.05 (H) x 121.54 (V)	mm
Pixel Pitch	0.1582 (H) x 0.1582 (V)	mm
Driver IC	NT51008M+NT39212Fx2	-
Operation Temperature	-10~50	°C
Storage Temperature	-20~60	°C

1.2 Touch Panel Information

Item	Specification
Touch Structure	G+G
Bonding Type with LCM	Perimeter Bonding
Driver IC	ILI2511
Interface	USB
Touch Count Max	10 Points
Surface treatment	-
Surface hardness	6H
I2C slave address	0x82
Origin of coordinate	Top Left Corner

Note1: Requirements on environmental protection RoHS compliant.



2. Absolute Maximum Ratings

Item	Symbol	MIN.	MAX.	Unit	Note
Analog Supply voltage	VDD	-0.3	5.0	V	Note 1

Note 1: Permanent damage may occur to the LCD module if beyond this specification.

Functional operation should be restricted to the conditions described under normal operating conditions.

3. Electrical Characteristics

3.1 Recommended Operating Condition for TFT LCD

Item	Symbol	Min.	Typ.	Max.	Unit	Note
Analog Supply voltage	VDD	3.0	3.3	3.6	V	
Analog supply current	I_{VDD}	-	TBD	-	mA	VDD=3.3V
Power supply for LCD	AVDD	9.8	10	10.2	V	
	VGH	18.4	18.9	19.4	V	
	VGL	-8.3	-7.8	-7.3	V	
	VCOM	4.2	4.7	5.2	V	
Logic input voltage	VIH	$0.7 \cdot VDD$	-	VDD	V	
	VIL	GND	-	$0.3 \cdot VDD$	V	

3.2 Recommended Driving Condition for Backlight

Item	Symbol	Min.	Typ.	Max.	Unit	Note
Driving Current	I_F	-	540	-	mA	
Driving Voltage	V_F	8.1	-	10.2	V	
Power consumption	W_{BL}	4.374	-	5.508	W	
LED Life-Time	N/A	-	50,000	-	Hours	Ta=25°C Note 1

Note 1: LED lifetime is defined as the module brightness decay 50% of original brightness at Ta=25 degree, typical current.



Note 2:LED circuit :

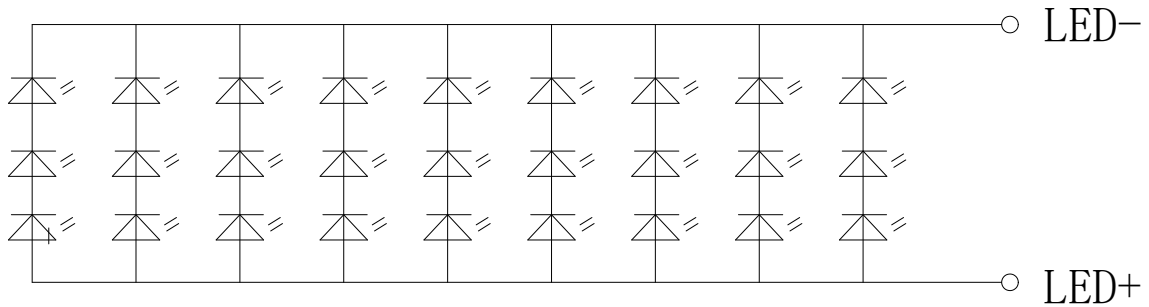

3.3 Touch Panel

Item	Symbol	Min.	Typ.	Max.	Unit	Note
Power Supply voltage	VDD	-	5.0	-	V	
Analog supply current	I_{VDD}	-	TBD	-	mA	VDD=5.0V
Input high-level voltage	V _{IH}	0.7*VDD	-	VDD	V	
Input low -level voltage	V _{IL}	GND	-	0.3*VDD	V	



4. Interface Pin Assignment

4.1 LCM Pin Assignment

No.	Symbol	Description
1	VCOM	Common voltage
2	VDD	3.3V Power
3	VDD	3.3V Power
4	NC	Not connect
5	RESET	Global reset pin
6	STBYB	Standby mode normally pull high STBYB="1"normal operation STBYB = "0", timing controller, source driver will turn off, all output are High-Z
7	GND	Ground
8	RXIN0-	Negative LVDS differential data input
9	RXIN0+	Positive LVDS differential data input
10	GND	Ground
11	RXIN1-	Negative LVDS differential data input
12	RXIN1+	Positive LVDS differential data input
13	GND	Ground
14	RXIN2-	Negative LVDS differential data input
15	RXIN12+	Positive LVDS differential data input
16	GND	Ground
17	RXCLK-	Negative LVDS differential clock input
18	RXCLK+	Positive LVDS differential clock input
19	GND	Ground
20	RXIN3-	Negative LVDS differential data input
21	RXIN3+	Positive LVDS differential data input
22	GND	Ground
23	NC	Not connect
24	NC	Not connect
25	GND	Ground
26	NC	Not connect
27	DIMO	Backlight CABC controller signal output
28	SELB	6bit/8bit mode select (NOTE1)
29	AVDD	Power for Analog Circuit
30	GND	Ground
31	NC	Not connect
32	NC	Not connect
33	L/R	Horizontal inversion, Normally pull high



34	U/D	Vertical inversion, Normally pull high.
35	VGL	Gate off Voltage
36	CABCEN1	CABC H/W enable (Note2)
37	CABCEN0	CABC H/W enable (Note2)
38	VGH	Gate on Voltage
39	NC	Not connect
40	NC	Not connect

Note1: If LVDS input data is 6 bits, selb must be set to High

If LVDS input data is 8 bits, selb must be set to Low

Note2: When CABC_EN="00", CABC OFF(Default mode)

When CABC_EN="01", user interface image

When CABC_EN="10", still picture

When CABC_EN="11", moving image

When CABC off, don't connect DIMO, else connect it to backlight

4.2 Touch FPC Pin Assignment

No.	Symbol	Description
1	GND	Ground
2	D+	Data+ input
3	D-	Data- input
4	VDD/5V	Power supply (5V)



5. Interface Characteristics

5.1 Power Sequence

Power-On/Off Timing Sequence:

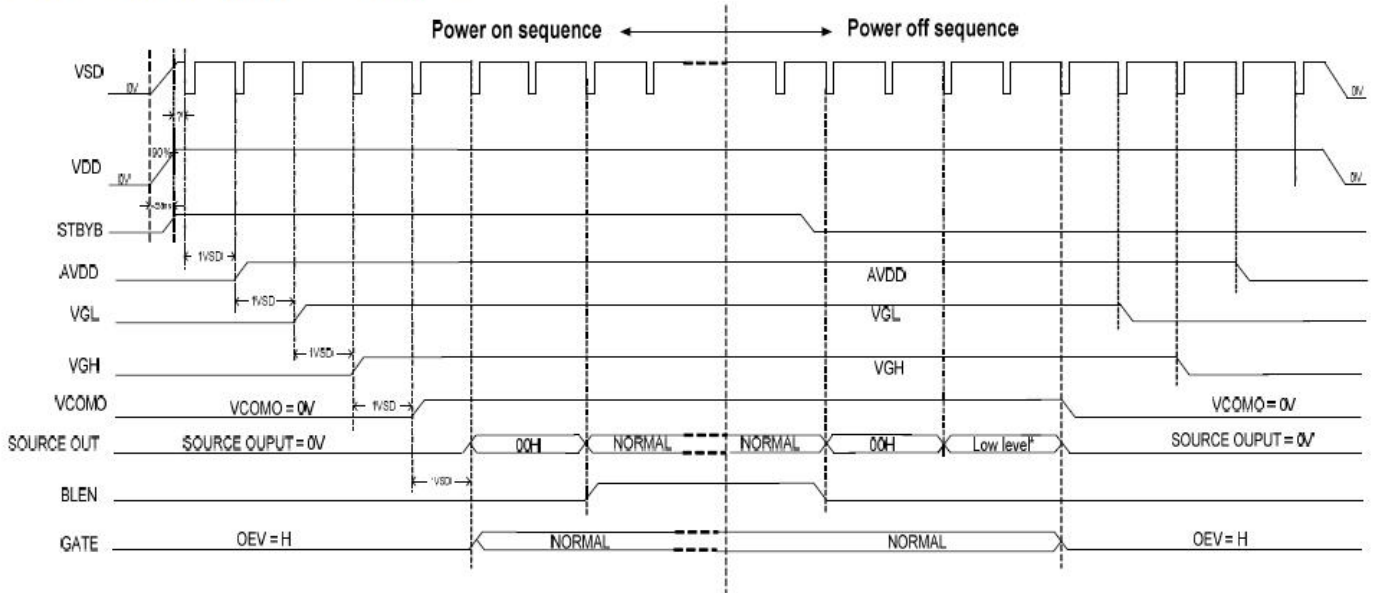

Enter and Exit Standby Mode Sequence:

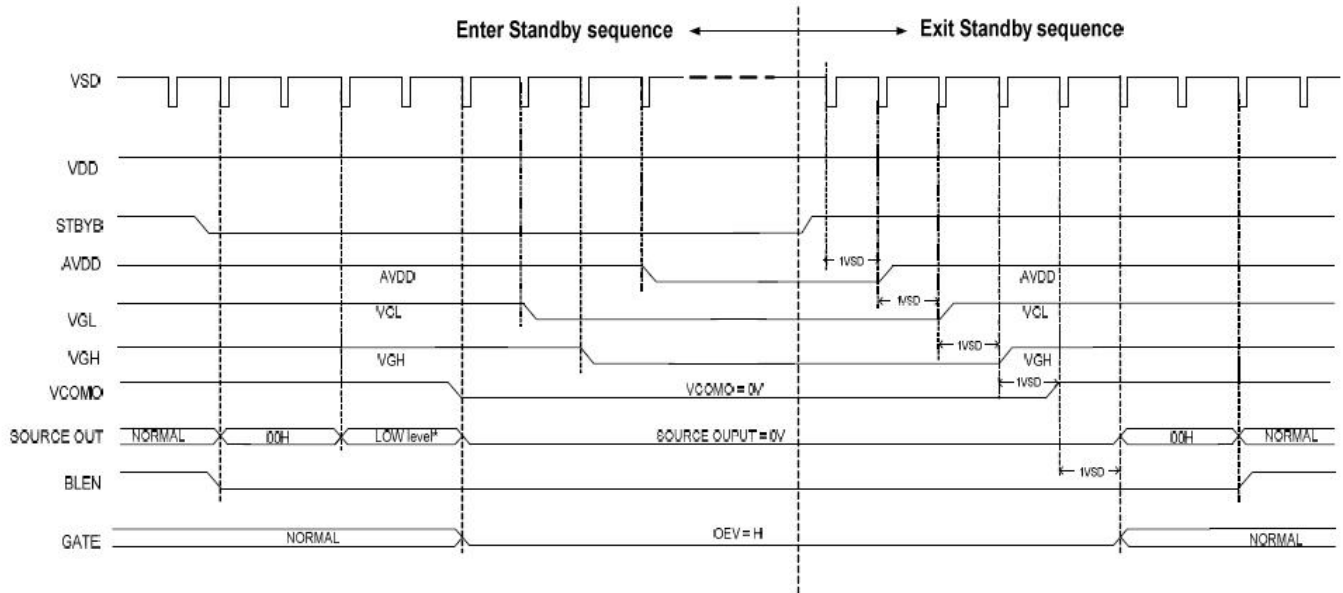



5.2 Data Input Format for LVDS

6bit LVDS input

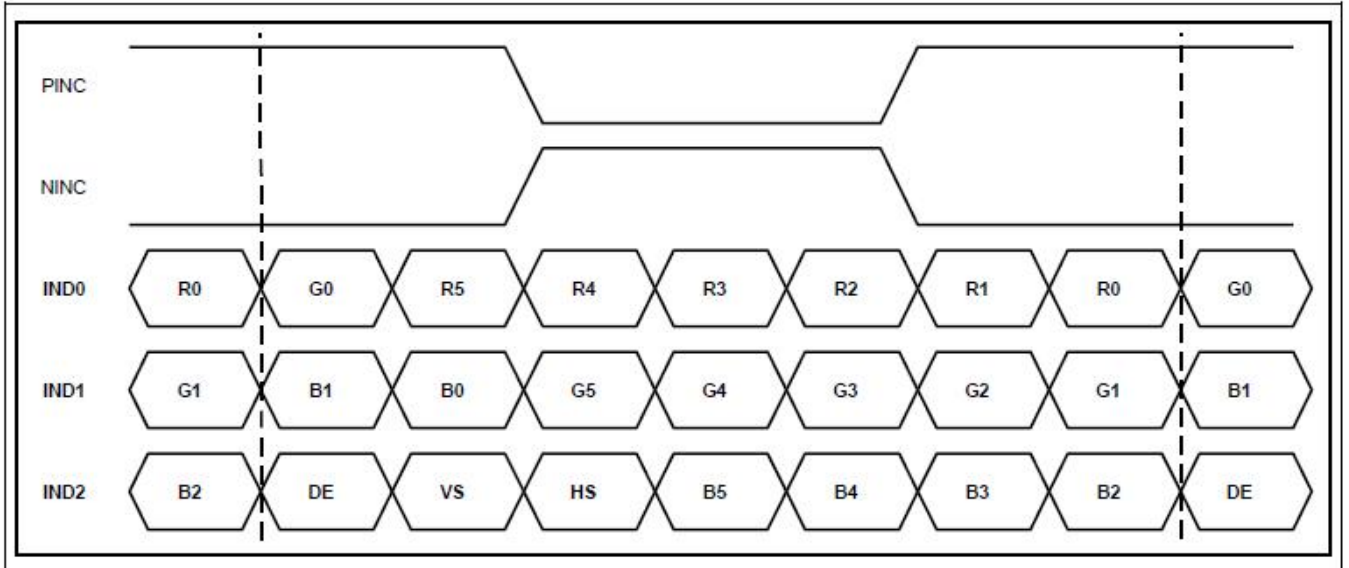

8-bit LVDS input (HSD='L')

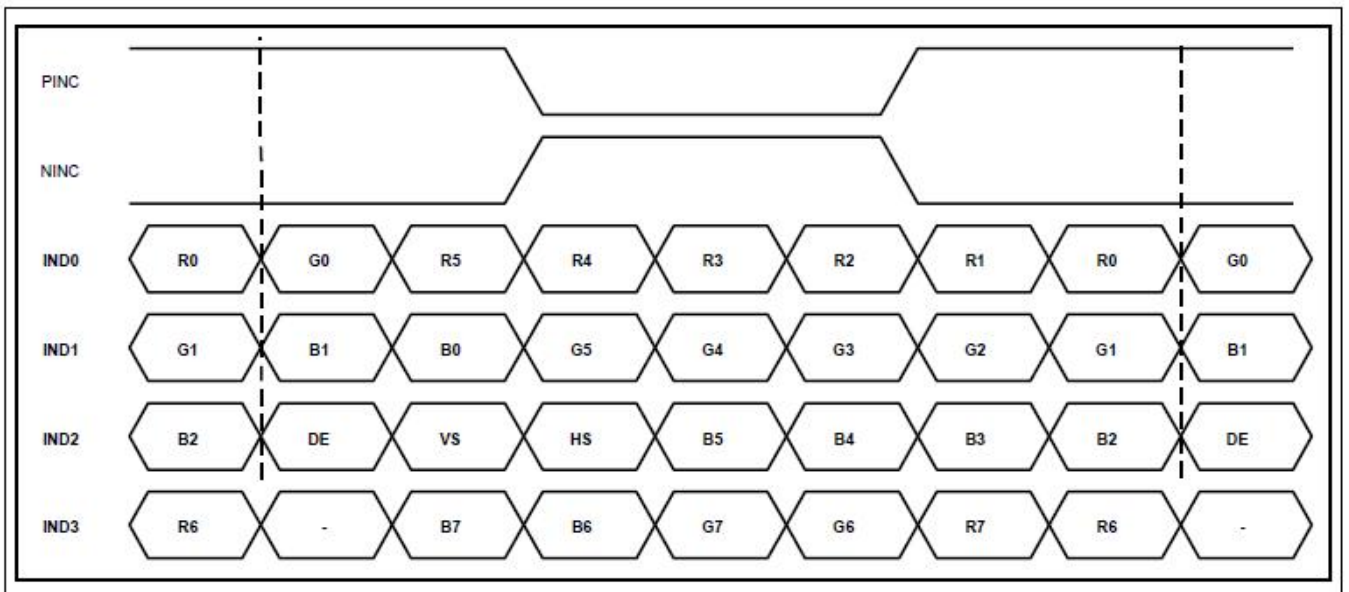



5.3 AC Electrical Characteristics

LVDS mode

Parameter	Symbol	Min.	Typ.	Max.	Unit	Condition
Clock frequency	R_{xFCLK}	20		71	MHZ	
Input data skew margin	T_{RSKM}	500			pS	$ V_{ID} = 400mV$ $R_{xVCM} = 1.2V$ $R_{xFCLK} = 71 MHz$
Clock high time	T_{LVCH}		$4/(7 * R_{xFCLK})$		ns	
Clock low time	T_{LVCL}		$3/(7 * R_{xFCLK})$		ns	
PLL wake-up time	T_{enPLL}			150	uS	

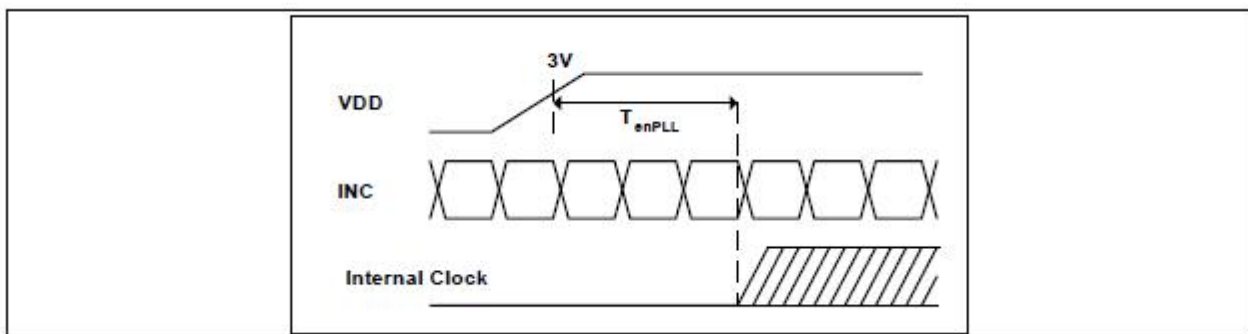
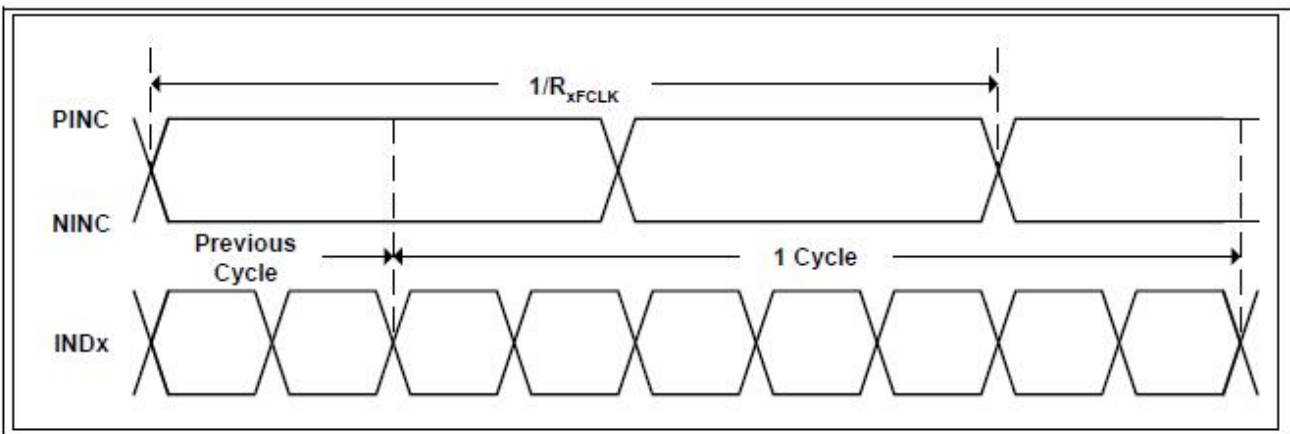

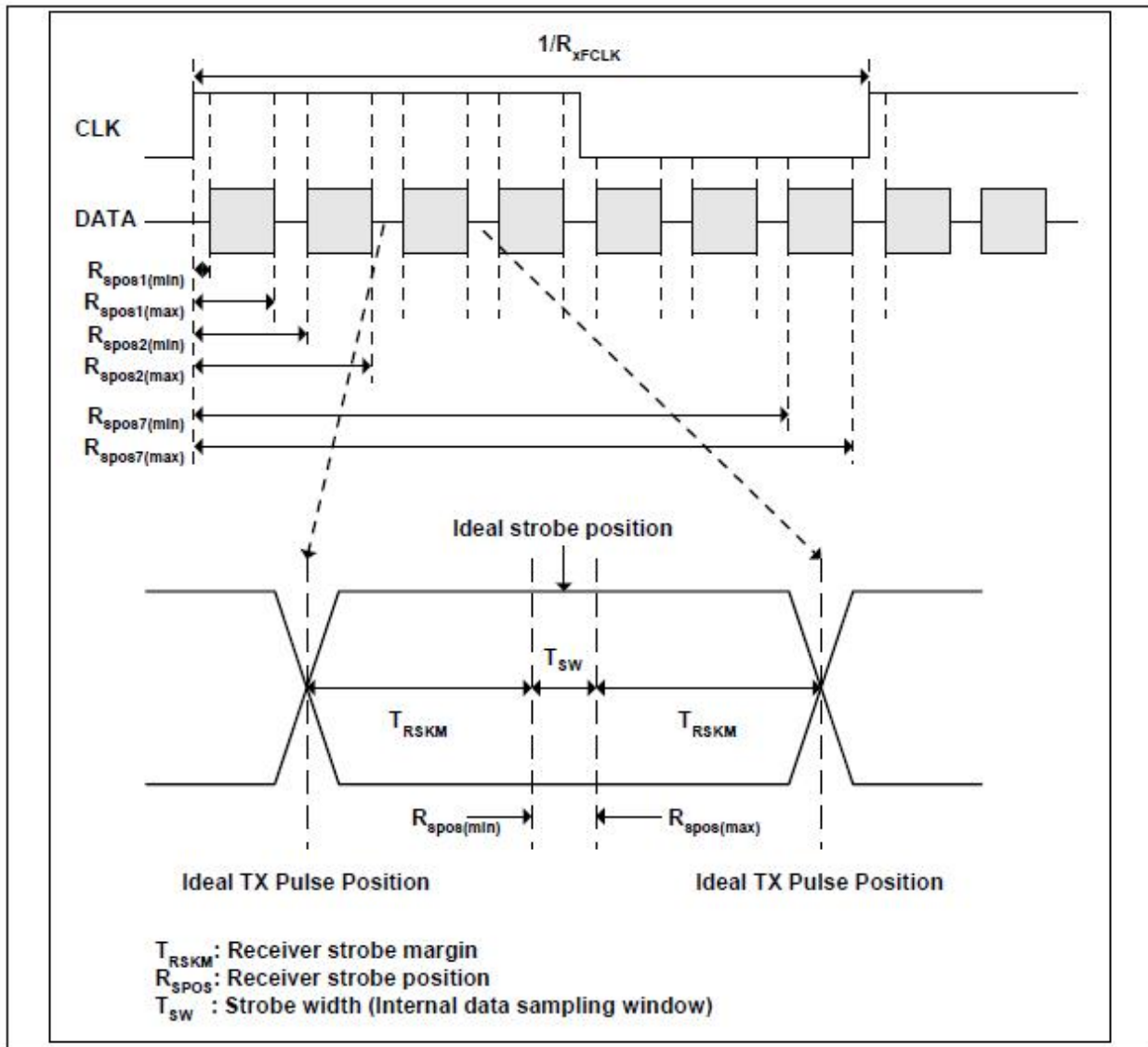

SSC tolerance of LVDS receiver						
Symbol	parameter	condition	Min.	Typ.	Max.	Units
SSCMF	Modulation Frequency		23		93	KHz
SSCMR	Modulation Rate	LVDS clock = 71MHz center spread			±3	%



Output Timing Table

Parameter	Symbol	Min.	Typ.	Max.	Unit	Conditions
DCLK Frequency	Fclk	-	65	71	MHz	VDD = 2.3V ~3.6V
DCLK Cycle Time	Tclk	14.1	15.4	-	ns	
DCLK Pulse Duty	Tcwh	40	50	60	%	Tclk
Time from HSD to Source Output	Thso	-	64	-	DCLK	
Time from HSD to LD	Thld	-	64	-	DCLK	
Time from HSD to STV	Thstv	-	2	-	DCLK	
Time from HSD to CKV	Thckv	-	20	-	DCLK	
Time from HSD to OEV	Thoev	-	4	-	DCLK	
LD Pulse Width	Twid	-	10	-	DCLK	
CKV Pulse Width	Twckv	-	66	-	DCLK	
OEV Pulse Width	Twoev	-	74	-	DCLK	

Timing Diagram

1. Input Clock and Data Timing Diagram

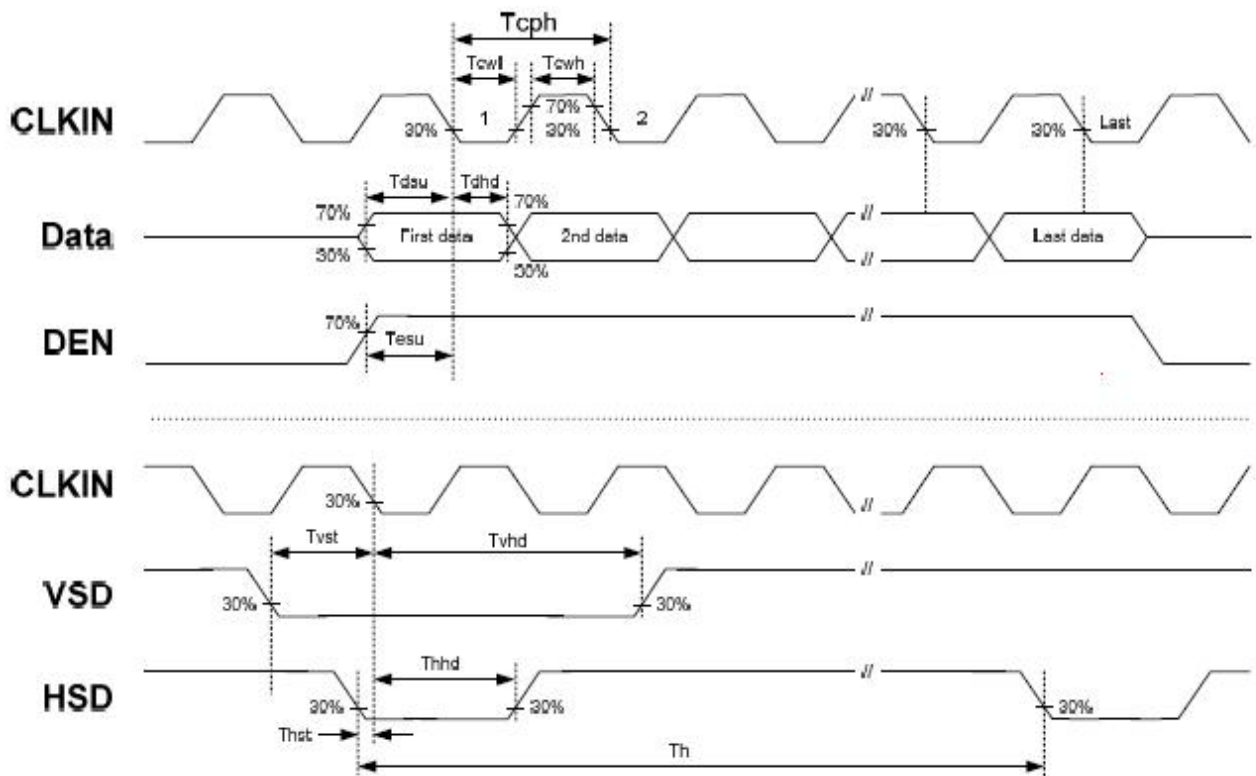



6. Optical Specifications

Item	Symbol	Condition	Min.	Typ.	Max.	Unit	Note
Viewing Angle (CR≥10) B/L ON	θ_T	$\Phi=90^\circ$ (12 o'clock)	75	80	-	deg	Note2
	θ_B	$\Phi=270^\circ$ (6 o'clock)	75	80	-	deg	Note2
	θ_L	$\Phi=180^\circ$ (9 o'clock)	75	80	-	deg	Note2
	θ_R	$\Phi=0^\circ$ (3 o'clock)	75	80	-	deg	Note2
Response Time	T_{ON}	Normal $\theta=\Phi=0^\circ$	-	12	17	msec	Note4
	T_{OFF}		-	12	17	msec	Note4
Contrast Ratio	CR		600	800	-	-	Note1 Note3
Color Chromaticity	W_X		TBD	TBD	TBD	-	Note1 Note5
	W_Y		TBD	TBD	TBD	-	Note1 Note5
Luminance	L		700	800	-	cd/m ²	Note1 Note7
Luminance Uniformity	Y_U		75	80	-	%	Note1 Note6
NTSC	-		45	50	-	%	-

Note 1: Definition of optical measurement system

The optical characteristics should be measured in dark room. After 5 minutes operation, the optical properties are measured at the center point of the LCD screen. All input terminals LCD panel must be ground when measuring the center area of the panel.

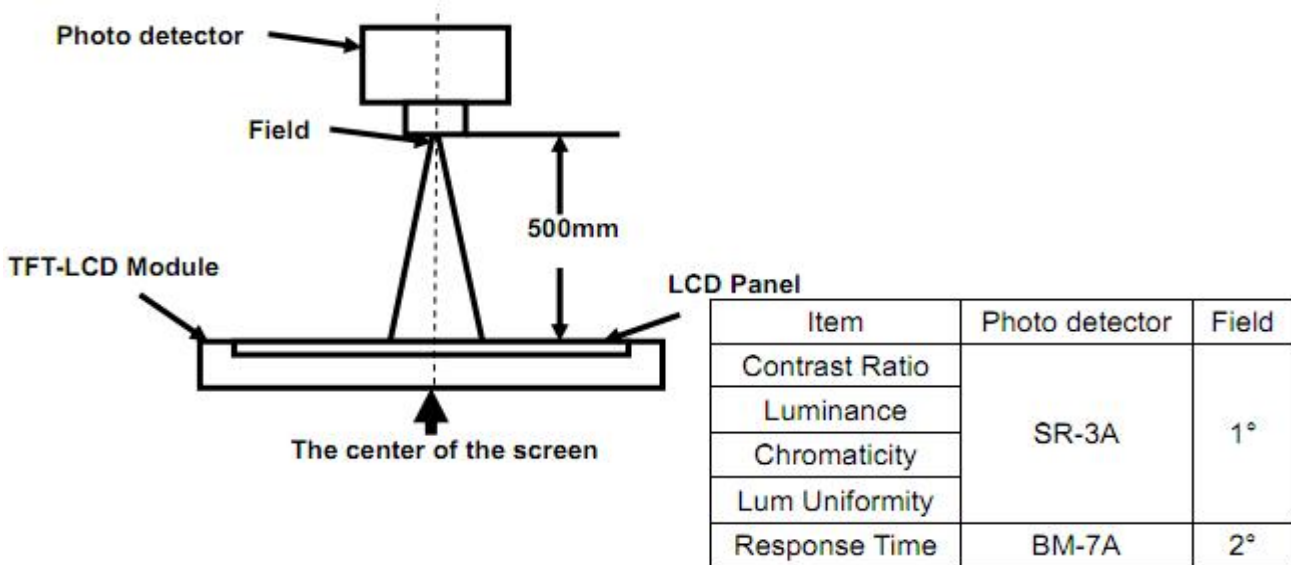

Fig 1

Note 2: Definition of viewing angle range and measurement system.
viewing angle is measured at the center point of the LCD by CONOSCOPE(ergo-80).

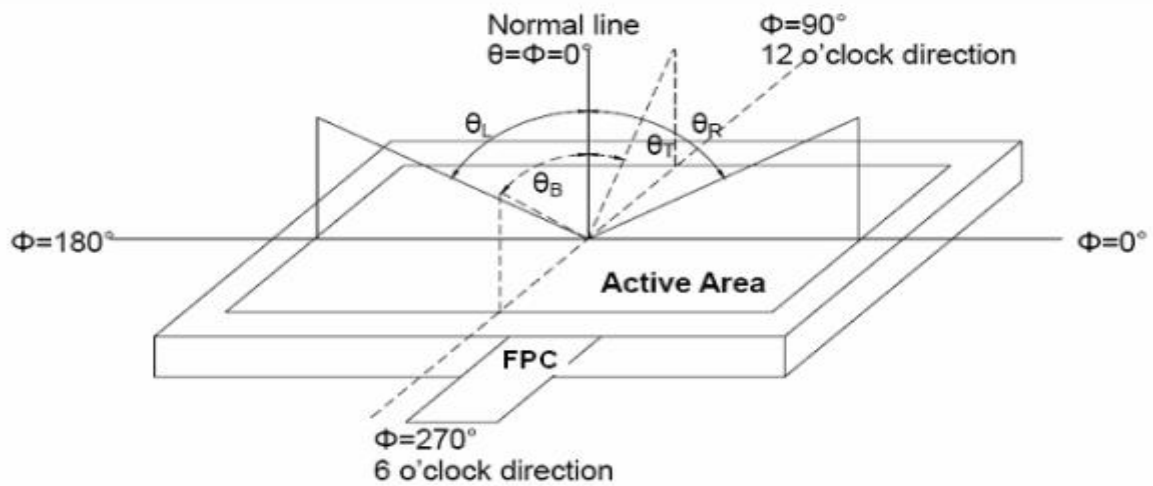

Fig 2 Definition of viewing angle

Note 3: Definition of contrast ratio

$$CR = \frac{\text{Luminance with all pixels white}}{\text{Luminance with all pixels black}}$$



Note 4: Definition of Response time

The response time is defined as the LCD optical switching time interval between “White” state and “Black” state. Rise time (T_{ON}) is the time between photo detector output intensity changed from 90% to 10%. And fall time (T_{OFF}) is the time between photo detector output intensity changed from 10% to 90%.

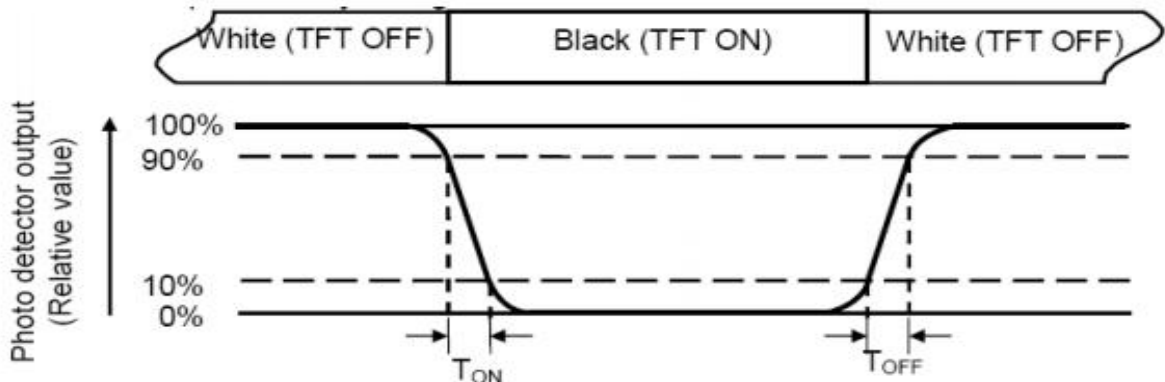

Note 5: Definition of color chromaticity (CIE1931)

Color coordinates measured at center point of LCD.

Note 6: Definition of Luminance Uniformity

The luminance uniformity in surface luminance is determined by measuring luminance at each test position 1 through n, and then dividing the maximum luminance of n points luminance by minimum luminance of n points luminance. For more information see FIG.3-a/b

Note 7: Surface luminance is the luminance with all pixels displaying white.

L_v = Average Surface Luminance with all white pixels ($P_1, P_2, P_3, \dots, P_n$)

For more information see FIG.3-a/b

Note 8: Size : $S \leq 5"$ (see Figure a) A : 5 mm B : 5 mm. H, V : Active area

Light spot size $\varnothing = 5\text{mm}$ (BM-5) or $\varnothing = 7.7\text{mm}$ (BM-7) 50cm distance or test spot position : see Figure a.

measurement instrument : TOPCON's luminance meter SR-3A or BM-7 or compatible (see Figure 1).

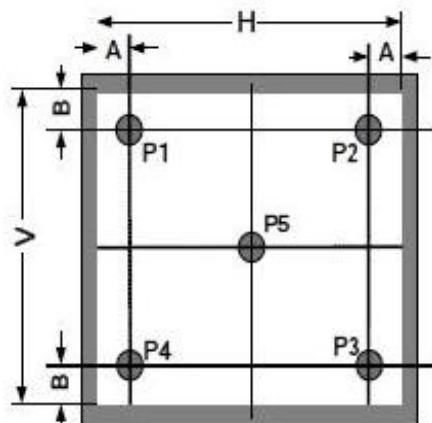

Fig. 3-a Definition of points



$5'' < S \leq 12.3''$ (see Figure b) . H,V : Active area

Light spot size $\varnothing = 5\text{mm}$ (BM-5) or $\varnothing = 7.7\text{mm}$ (BM-7) 50cm distance or compatible distance from the LCD surface to detector lens. test spot position : see Figure b.

measurement instrument : TOPCON's luminance meter SR-3A or BM-7 or compatible (see Figure 1).

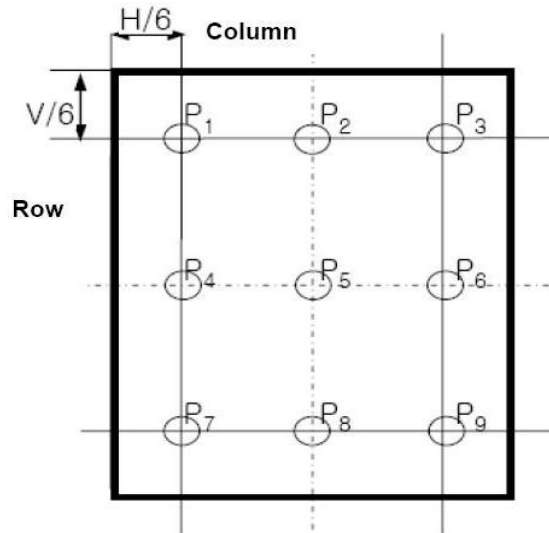

Fig. 3-b Definition of points



7. Reliability Test Items

Test Item	Test Conditions
High Temperature Storage	Ta= +60°C 96hrs
Low Temperature Storage	Ta= -20°C 96hrs
High Temperature Operation	Ta= +50°C 96hrs
Low Temperature Operation	Ta= -10°C 96hrs
High Temperature and Humidity Storage	Ta= +60°C, 90% RH 96hrs
Thermal Shock (Non-operation)	-20°C/30 min ~ +60°C/30 min for 20 cycles Start with cold temperature end with high temperature
Electro Static Discharge	Contact = ± 4 kV, class B Air = ± 8 kV, class B R=330Ω,C=150pF
Vibration	Sweep: 10Hz~55Hz~10Hz Stroke: 1.5mm 2 hrs for each direction of X .Y. Z.
Mechanical Shock	60G 6ms,±X,±Y,±Z 3 times for each direction
Package Drop Test	Height: 60 cm 1 corner, 3 edges, 6 surfaces

Notes: The test result shall be evaluated after the sample has been left at room temperature and humidity for 2 hours without load. No condensation shall be accepted. The sample will not be accepted if appear these defects:

- 1). Air bubble in the LCD
- 2). Seal leak or Glass crack
- 3). Non display or abnormal display
- 4). Brightness reduction >50%



9. Packing

Packing Method

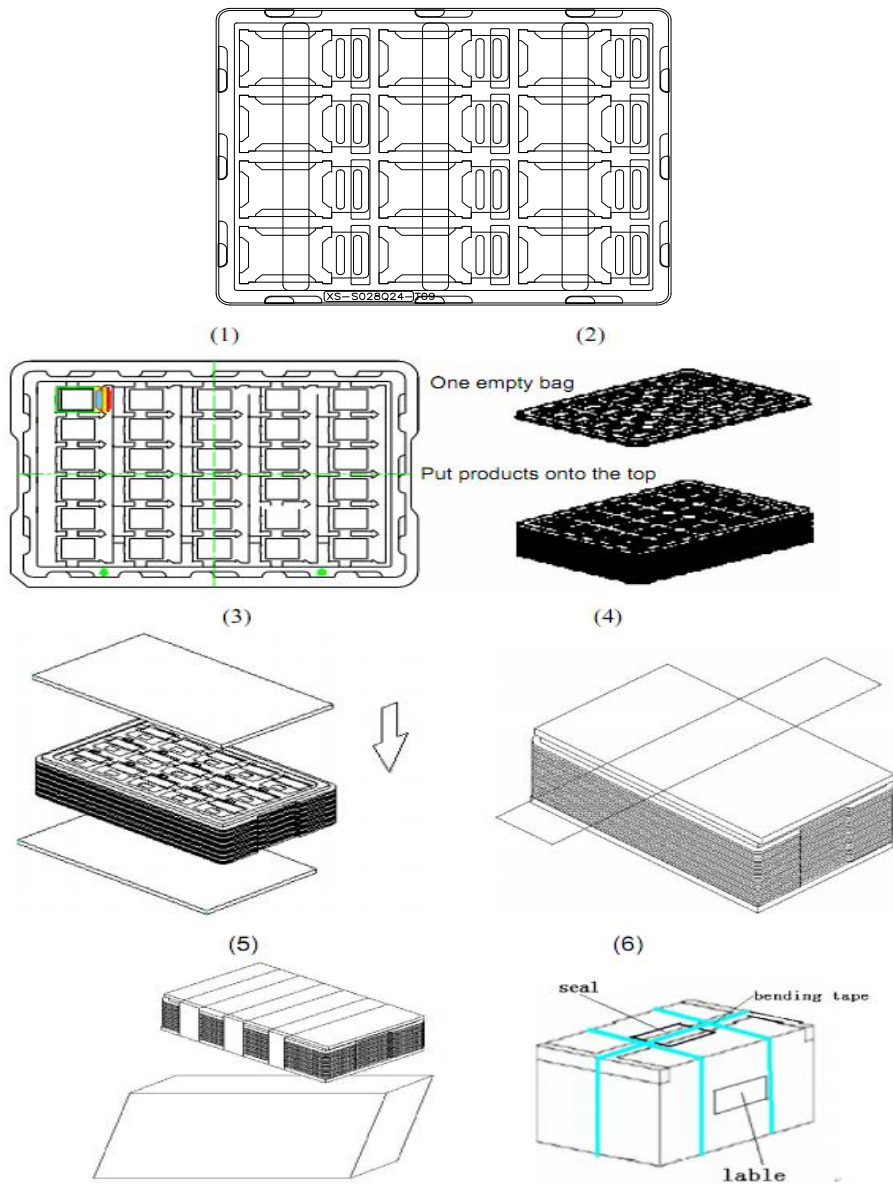

Steps:

1. Put module into tray cavity
2. Tray stacking
3. Put 1 cardboard under the tray stack and 1 cardboard above
4. Fix the cardboard to the tray stack with adhesive tape
5. Put the tray stack into carton
6. Carton sealing with adhesive tape



10. Precautions for Use of LCD modules

10.1 Handling Precautions

10.1.1. The display panel is made of glass. Do not subject it to a mechanical shock by dropping it from a high place, etc.

10.1.2. If the display panel is damaged and the liquid crystal substance inside it leaks out, be sure not to get any in your mouth, if the substance comes into contact with your skin or clothes, promptly wash it off using soap and water.

10.1.3. Do not apply excessive force to the display surface or the adjoining areas since this may cause the color tone to vary.

10.1.4. The polarizer covering the display surface of the LCD module is soft and easily scratched. Handle this polarizer carefully.

10.1.5. If the display surface is contaminated, breathe on the surface and gently wipe it with a soft dry cloth. If still not completely clear, moisten cloth with one of the following solvents:

- Isopropyl alcohol
- Ethyl alcohol

Solvents other than those mentioned above may damage the polarizer. Especially, do not use the following:

- Water
- Ketene
- Aromatic solvents

10.1.6. Do not attempt to disassemble the LCD Module.

10.1.7. If the logic circuit power is off, do not apply the input signals.

10.1.8. To prevent destruction of the elements by static electricity, be careful to maintain an optimum work environment.

10.1.8.1. Be sure to ground the body when handling the LCD Modules.

10.1.8.2. Tools required for assembly, such as soldering irons, must be properly ground.

10.1.8.3. To reduce the amount of static electricity generated, do not conduct assembly and other work under dry conditions.

10.1.8.4. The LCD Module is coated with a film to protect the display surface. Be care when peeling off this protective film since static electricity may be generated.

10.2 Storage Precautions

10.2.1. When storing the LCD modules, avoid exposure to direct sunlight or to the light of fluorescent lamps.

10.2.2. The LCD modules should be stored under the storage temperature range if the LCD modules will be stored for a long time, the recommend condition is :

Temperature : 0°C ~40°C Relatively humidity: ≤80%

10.2.3. The LCD modules should be stored in the room without acid, alkali and harmful gas.

10.3 Transportation Precautions

The LCD modules should be no falling and violent shocking during transportation, and also should avoid excessive press, water, damp and sunshine.