



PRODUCT SPECIFICATION

KADI Model: KD101ZWX89FP-FC86-1

CUSTOMER Model: -

Description: 10.1 ” TFT-LCD Module with CTP

Version: 1.0

KADI	PREPARED BY	CHECKED BY	APPROVED BY
SIGNATURE			
DATE	2024.6.21	2024.6.21	2024.6.21

CUSTOMER APPROVAL	SIGNATURE	DATE



Contents

1. General Specifications	4
2. Absolute Maximum Ratings	5
3. Electrical Characteristics	5
4. Interface Pin Assignment	7
5. Interface Characteristics	9
6. Optical Specifications	9
7. Reliability Test Items	20
8. Mechanical Drawing	21
9. Packing	22
10. Precautions for Use of LCD modules	23



1. General Specifications

1.1 LCM General Information

Item	Specification	Unit
LCD Size	10.1	inch
Number of Pixels	1280 (H) RGB x 720 (V)	pixels
Display Mode	Normally Black	-
Viewing Direction	Free	o' clock
Interface	LVDS	-
Display Colors	16.7M	colors
Outline Dimension	260.00 (H) x 160.00 (V) x 8.15 (D)	mm
Active Area	224.64 (H) x 126.36 (V)	mm
Pixel Pitch	0.1755 (H) x 0.1755 (V)	mm
Driver IC	EK79202D	-
Operation Temperature	-30~85	°C
Storage Temperature	-30~85	°C

1.2 Touch Panel Information

Item	Specification
Touch Structure	G+G
Bonding Type with LCM	OCA Optical Bonding
Driver IC	ILI2511
Interface	USB&I2C
Touch Count Max	10 Points
Surface treatment	-
Surface hardness	6H
I2C slave address	0x82
Origin of coordinate	Top Left Corner

Note1: Requirements on environmental protection RoHS compliant.



2. Absolute Maximum Ratings

Item	Symbol	MIN.	MAX.	Unit	Note
Analog Supply voltage	VDD	-0.3	4.0	V	Note 1

Note 1: Permanent damage may occur to the LCD module if beyond this specification.

Functional operation should be restricted to the conditions described under normal operating conditions.

3. Electrical Characteristics

3.1 Recommended Operating Condition for TFT LCD

Item	Symbol	Min.	Typ.	Max.	Unit	Note
Analog Supply voltage	VDD	3.0	3.3	3.6	V	
Analog supply current	I_{VDD}	-	TBD	-	mA	VDD=3.3V
Logic input voltage	V _{IH}	0.7*VDD	-	VDD	V	
	V _{IL}	GND	-	0.3*VDD	V	

3.2 Recommended Driving Condition for Backlight

Item	Symbol	Min.	Typ.	Max.	Unit	Note
Driving Current	I_{BLU}	-	1000	-	mA	
Driving Voltage	V_{BLU}	-	12	-	V	
Power consumption	W_{BLU}	-	12	-	W	
LED Life-Time	N/A	-	50,000	-	Hours	Ta=25°C Note 1

Note 1: LED lifetime is defined as the module brightness decay 50% of original brightness at Ta=25 degree, typical current.



Note 2:LED circuit :

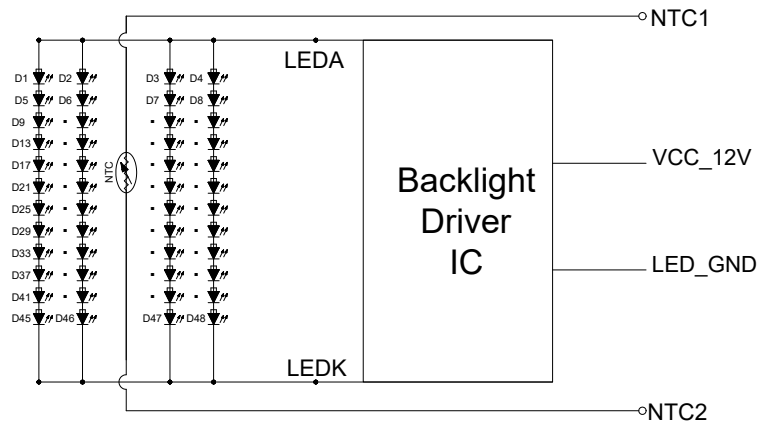

CIRCUIT DIAGRAM
 $V_F = 32.4 \sim 39.6V$; $I_F = 240mA$

3.3 Touch Panel (I2C)

Item	Symbol	Min.	Typ.	Max.	Unit	Note
Power Supply voltage	I2C_VDD 3.3V	-	3.3	-	V	
Analog supply current	$I_{I2C_VDD\ 3.3V}$	-	TBD	-	mA	I2C_VDD 3.3V=3.3V
Input high-level voltage	VIH	$0.7 * I2C_VDD$ 3.3V	-	I2C_VDD 3.3V	V	
Input low -level voltage	VIL	GND	-	$0.3 * I2C_VD$ D 3.3V	V	

3.4 Touch Panel (USB)

Item	Symbol	Min.	Typ.	Max.	Unit	Note
Power Supply voltage	USB_VDD (5V)	-	5.0	-	V	
Analog supply current	$I_{USB_VDD(5V)}$	-	TBD	-	mA	USB_VDD(5V) =5.0V
Input high-level voltage	VIH	$0.7 * USB_VD$ D(5V)	-	USB_VDD(5 V)	V	
Input low -level voltage	VIL	GND	-	$0.3 * USB_VD$ D(5V)	V	



4. Interface Pin Assignment

4.1 LCM Pin Assignment (Connector: TF31-40S-0.5SH(800))

No.	Symbol	Description
1	NC	No connection
2-3	VDD	Power supply
4-5	NC	No connection
6	STBYB	Standby mode. Normally pull high. STBYB = L, timing controller, source driver will turn off, all output are High-Z. STBYB = H, normal operation. (Default)
7	GND	Ground
8	Rxin0-	- LVDS differential data input
9	Rxin0+	+ LVDS differential data input
10	GND	Ground
11	Rxin 1-	- LVDS differential data input
12	Rxin1+	+ LVDS differential data input
13	GND	Ground
14	Rxin2-	- LVDS differential data input
15	Rxin2+	+ LVDS differential data input
16	GND	Ground
17	CLKIN-	-LVDS differential clock input
18	CLKIN+	+LVDS differential clock input
19	GND	Ground
20	Rxin3-	- LVDS differential data input
21	Rxin3+	+ LVDS differential data input
22	GND	Ground
23-24	NC	No connection
25	GND	Ground
26-27	NC	No connection
28	GND	Ground
29-30	NC	No connection
31	GND	Ground
32	NTC1	Thermistor pin1
33	NTC2	Thermistor pin2
34	NC	No connection
35	PWM	PWM dimming control
36	LED-EN	Backlight on/off control
37	NC	No connection
38-40	V _{BLU} 12V	Power for LED backlight (12V)



4.2 Touch FPC Pin Assignment (CN1 Connector: JST SM04B-SRSS-TB)

No.	Symbol	Description
1	USB_VDD (5V)	Power supply for CTP (5V)
2	USB_D-	Data- input
3	USB_D+	Data+ input
4	USB_GND	Ground

4.3 Touch FPC Pin Assignment (CN2 Connector: SM06B-SRSS-TB (side entry type))

No.	Symbol	Description
1	I2C_GND	Ground
2	I2C_VDD 3.3V	Power supply for CTP (3.3V)
3	I2C_RST	Reset Pin for CTP
4	I2C_SCL	I2C clock input for CTP
5	I2C_INT	Interrupt signal for CTP
6	I2C_SDA	I2C data input and output for CTP

4.3 Touch FPC Pin Assignment (CN3 Recommend connector: FH12-10S-0.5SH(55))

No.	Symbol	Description
1	USB_GND	Ground
2	USB_VDD (5V)	Power supply for CTP (5.0V)
3	USB D-	Data- input
4	USB D+	Data+ input
5	I2C_GND	Ground
6	I2C_VDD(3.3V)	Power supply for CTP (3.3V)
7	I2C_RST	Reset Pin for CTP
8	I2C_SCL	I2C clock input for CTP
9	I2C_INT	Interrupt signal for CTP
10	I2C_SDA	I2C data input and output for CTP



5. Interface Characteristics

5.1 Power Sequence

Power on sequence

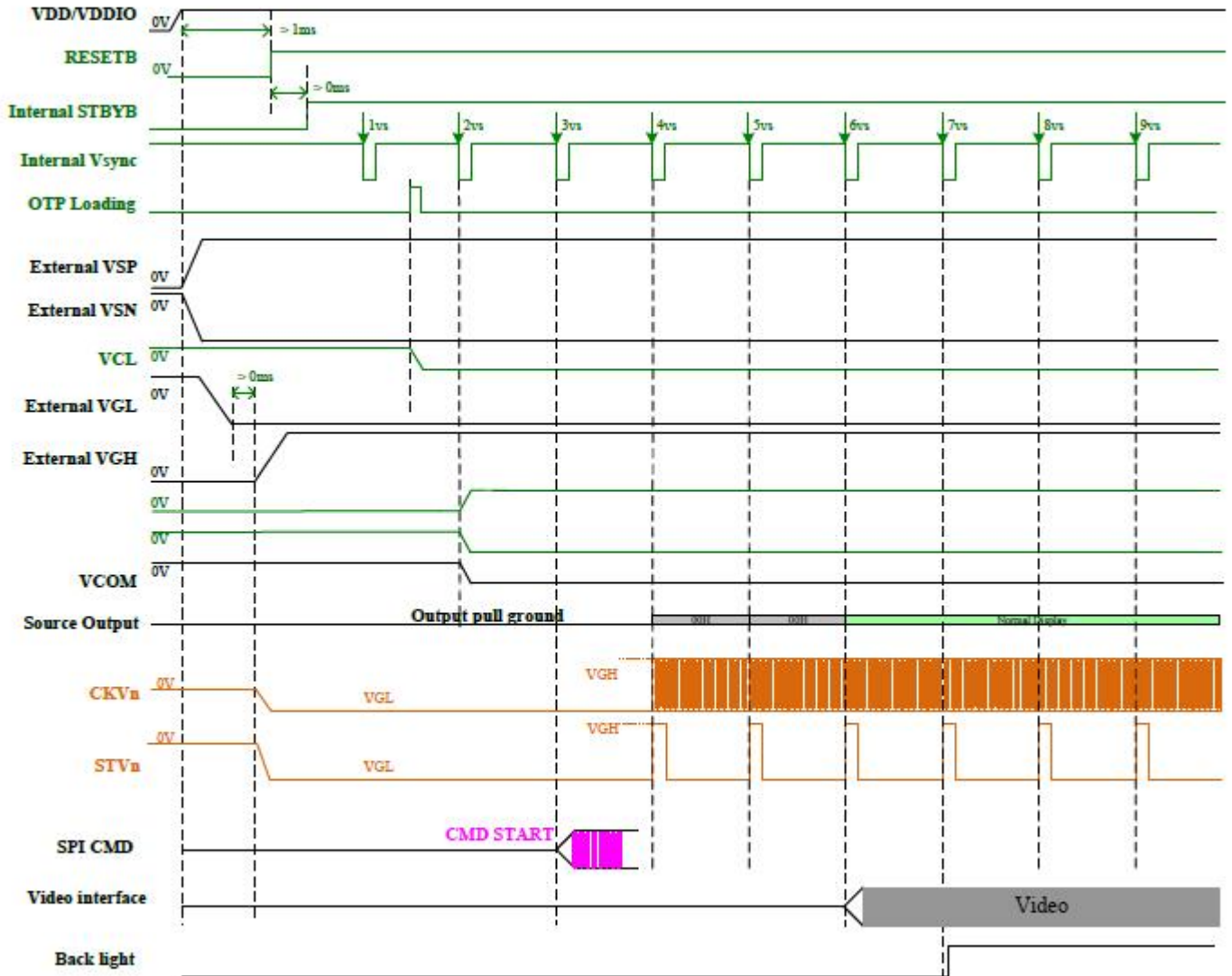

Note: Before Power on process is have to check all power input of external that is Gnd.



Power off sequence

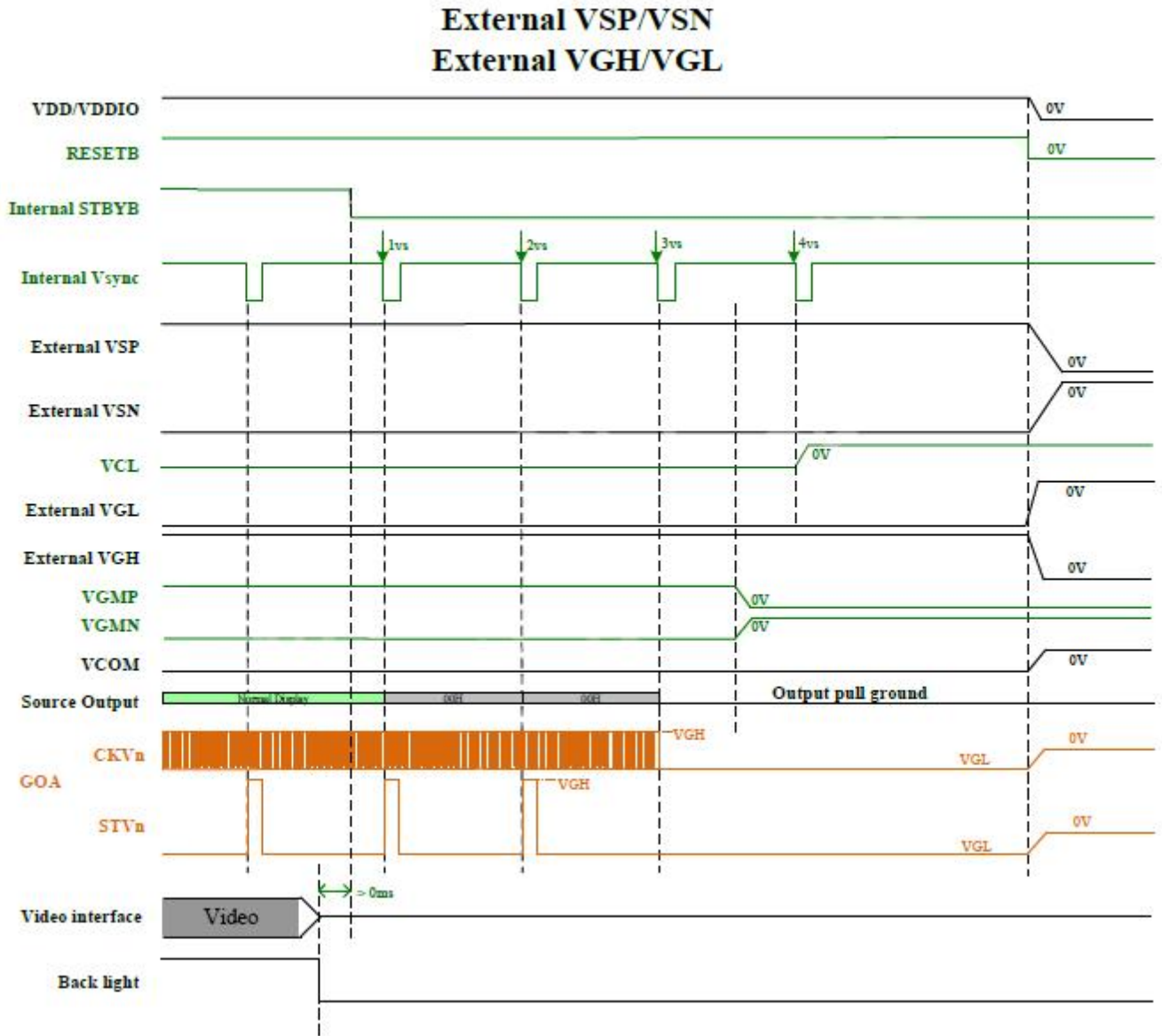



5.2 AC Characteristics

LVDS mode AC electrical characteristics

Parameter	Symbol	Spec.			Unit	Condition
		Min.	Typ.	Max.		
Clock frequency	R_{xFCLK}	30	-	TBD	MHz	Refer to input timing table for each display resolution
Input data skew margin	T_{RSKM}	500	-	-	ps	$ VID = 200mV$ $RxVCM = 1.2V$ $RxFCLK = 81MHz$
Clock high time	T_{LVCH}	-	$4/(7 * R_{xFCLK})$	-	ns	
Clock low time	T_{LVCL}	-	$3/(7 * R_{xFCLK})$	-	ns	
PLL wake-up time	T_{enPLL}	-	-	150	us	

Table 13.1: LVDS mode AC electrical characteristics

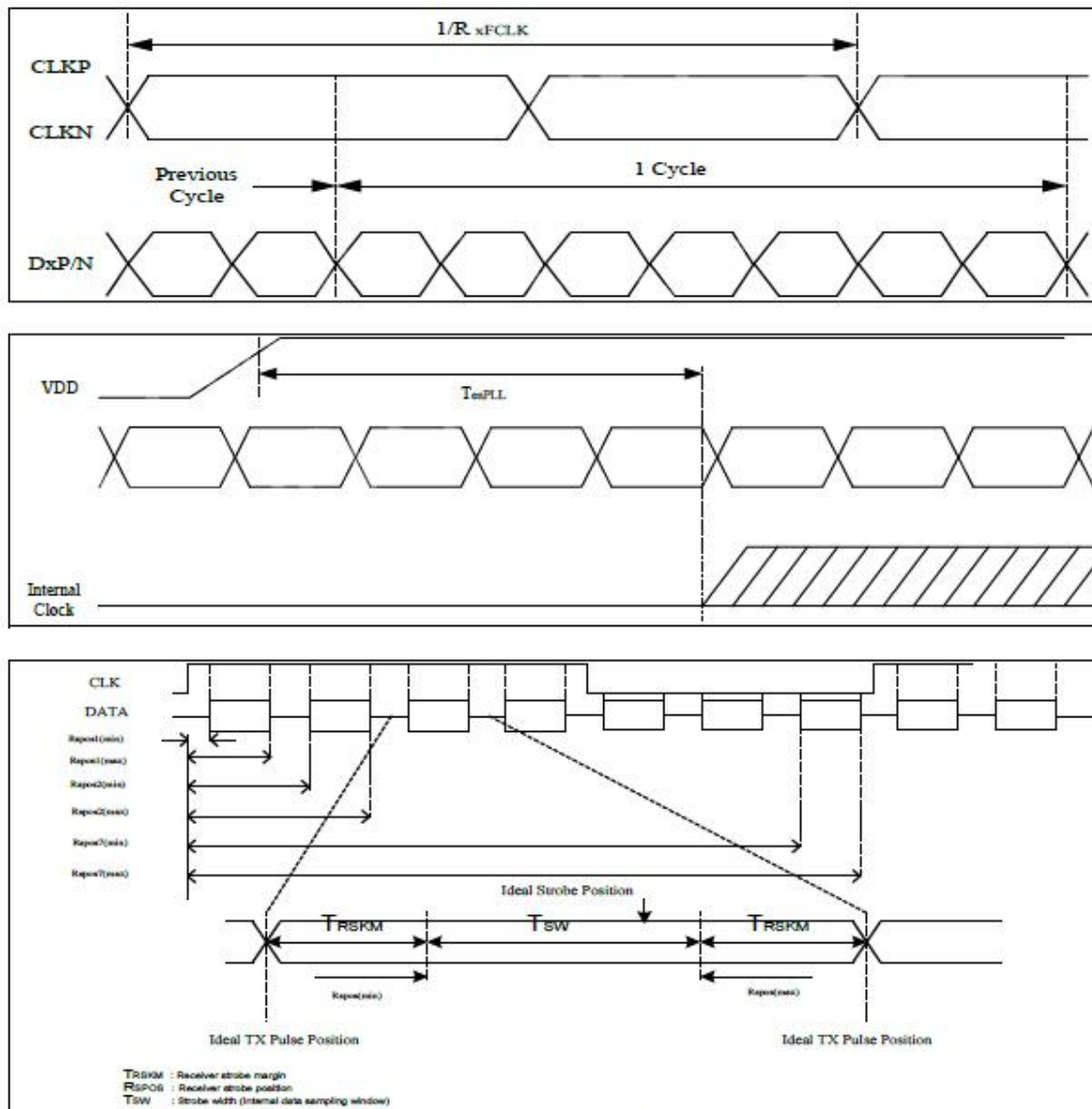

Figure 13.3: LVDS figure



Timing requirements for RESETB

When RESETB of the reset pin equals to Low, it will be in the condition of reset.
When it is in the condition of reset, it will make the device recover the initial set.

However, in order to avoid the reset noise cause reset, there is a mechanism to judge about whether the reset is needed or not.

The closed interval of Low can be shown as the following.

(Test condition: VDDIO=2.3V~3.6V, VSS=0V, T_A=-30 ~+85)

Parameter	Symbol	Conditions	Spec.			Unit
			Min.	Typ.	Max	
Reset low pulse width	Trst		20	-	-	μs

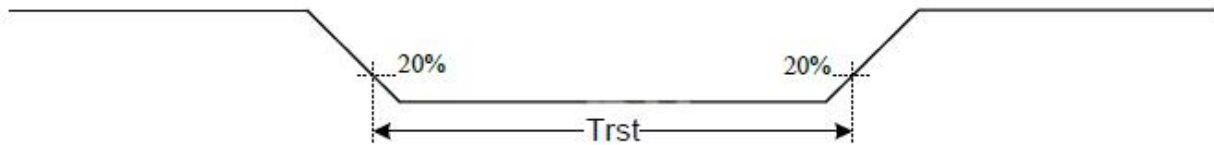

Figure 13.5: Reset timing



LVDS DC electrical characteristics

(VDD=VDDIO=VDDIF=2.3 to 3.6V, VSS=VSSA=VSS_IF=0V, TA=-30 to +85°C)

Parameter	Symbol	Min.	Typ.	Max.	Unit	Condition
Differential input high threshold voltage	R_{XVTH}	-	-	+0.1	V	$R_{XVCM}=1.2V$
Differential input low threshold voltage	R_{XVTL}	-0.1	-	-	V	
Input voltage range (singled-end)	R_{XVIN}	0.7	-	1.7	V	
Differential input common mode voltage	R_{XVCM}	1	1.2	1.4	V	$ V_{ID} =0.2$
Differential input impedance	Z_{ID}	80	100	125	ohm	
Differential input voltage	$ V_{ID} $	0.2	-	0.6	V	
Differential input leakage current	I_{LCLVDS}	-10	-	+10	uA	
LVDS Digital Operating Current	I_{VDD}	-	15	20	mA	$F_{CLK}=80MHz, VDD=3.3V$, Input pattern: 55h->Aah->55h->Aah
LVDS Digital Stand-by Current	I_{ST}	-	-	250	uA	Clock & all Functions are stopped

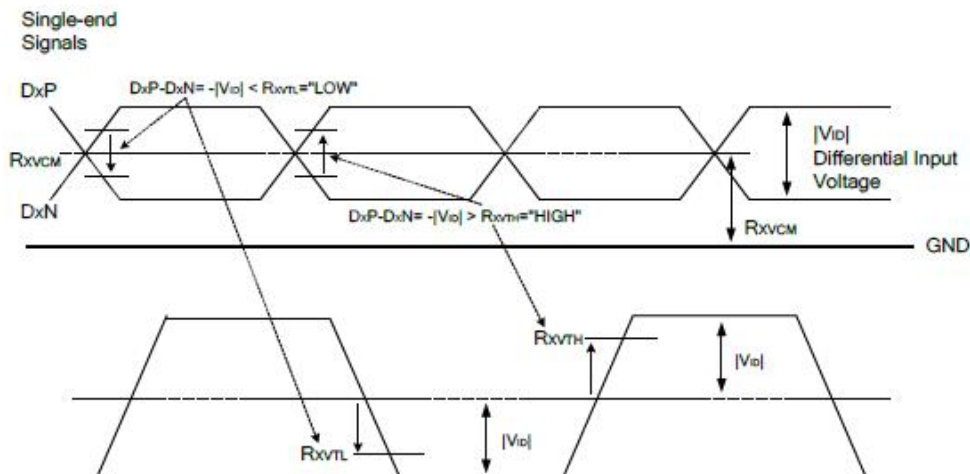



5.3 LVDS interface

Data input format for LVDS

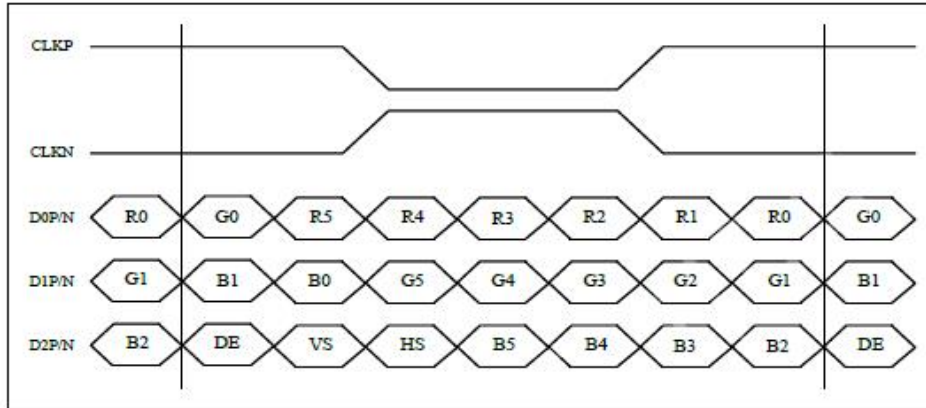

6-bit LVDS input (LVBIT=L, LVFMT=Don't care)

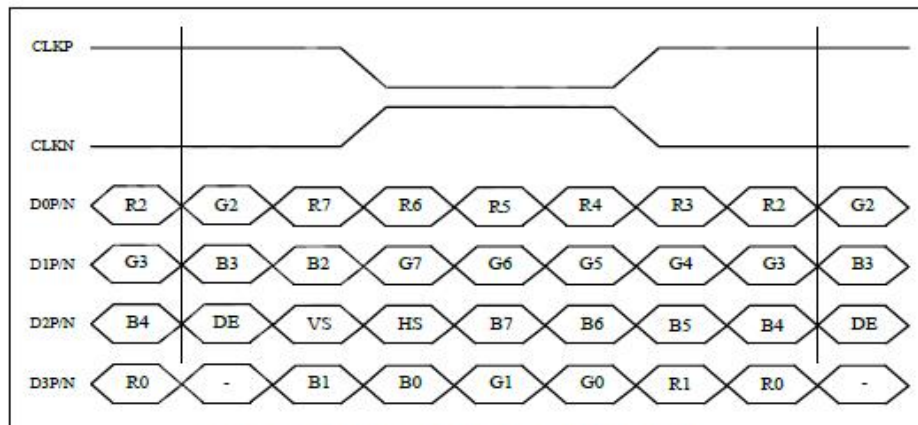

8-bit LVDS input (LVBIT=H, LVFMT=L)

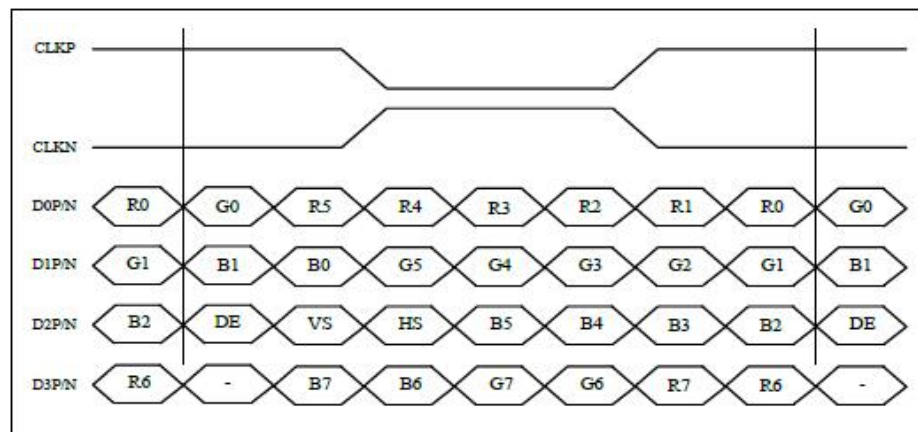

8-bit LVDS input(LVBIT=H, LVFMT=H)



For 1280RGBx720

Parameter	Symbol	Value			Unit
		Min.	Typ.	Max.	
DCLK frequency @Frame rate=60Hz (LVDS)	F _{DCLK}	61.6	65.5	71.3	MHz
HSYNC period time	T _H	1380	1440	1500	DCLK
Horizontal display area	T _{HD}	1280			DCLK
HSYNC pulse width	Min.	2			
	Typ.	-			
	Max.	40			
HSYNC back porch(with pulse width)	T _{HBP}	88	88	88	DCLK
HSYNC front porch	T _{HFP}	12	72	132	DCLK
VSYNC period time	T _V	744	758	792	H
Vertical display area	T _{VD}	720			H
VSYNC pulse width	Min.	2			H
	Typ.	-			
	Max.	20			
VSYNC back porch(with pulse width)	T _{VBP}	23	23	23	H
VSYNC front porch	T _{VFP}	1	15	49	H



6. Optical Specifications

Item	Symbol	Condition	Min.	Typ.	Max.	Unit	Note
Viewing Angle (CR≥10) B/L ON	θ_T	$\Phi=90^\circ$ (12 o'clock)	75	85	-	deg	Note2
	θ_B	$\Phi=270^\circ$ (6 o'clock)	75	85	-	deg	Note2
	θ_L	$\Phi=180^\circ$ (9 o'clock)	75	85	-	deg	Note2
	θ_R	$\Phi=0^\circ$ (3 o'clock)	75	85	-	deg	Note2
Response Time	T_{ON}	Normal $\theta=\Phi=0^\circ$	-	10	15	msec	Note4
	T_{OFF}		-	10	15	msec	Note4
Contrast Ratio	CR		900	1200	-	-	Note1 Note3
Color Chromaticity	W_X		TBD	TBD	TBD	-	Note1 Note5
	W_Y		TBD	TBD	TBD	-	Note1 Note5
Luminance	L		900	1000	-	cd/m ²	Note1 Note7
Luminance Uniformity	Y_U		75	80	-	%	Note1 Note6
NTSC	-		67	70	-	%	-

Note 1: Definition of optical measurement system

The optical characteristics should be measured in dark room. After 5 minutes operation, the optical properties are measured at the center point of the LCD screen. All input terminals LCD panel must be ground when measuring the center area of the panel.

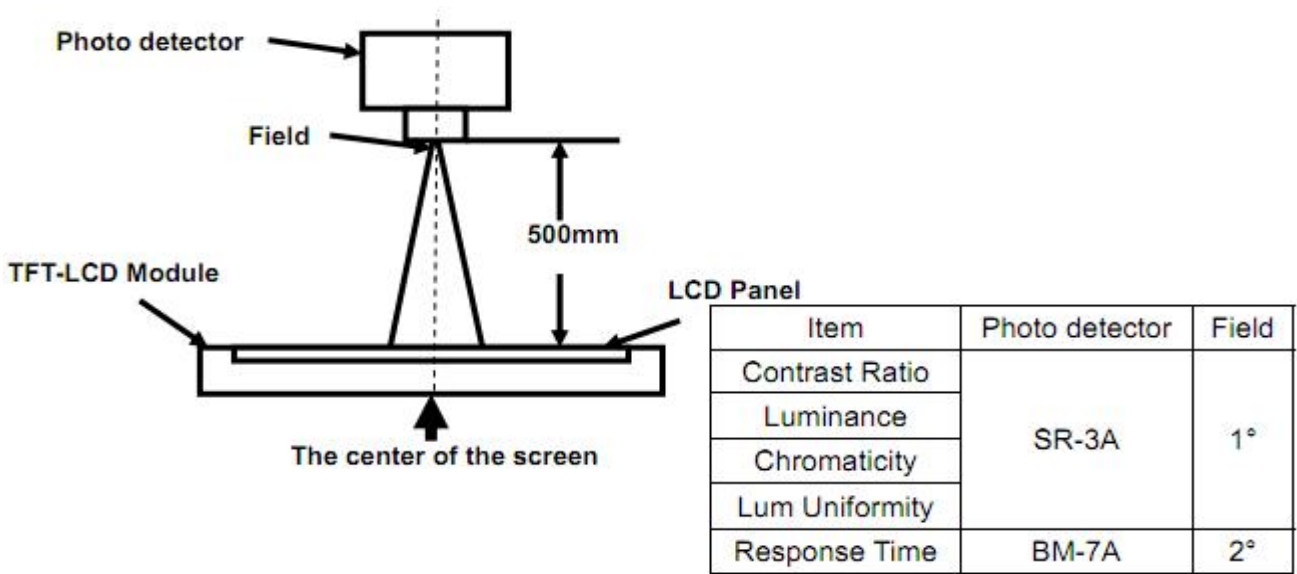

Fig 1

Note 2: Definition of viewing angle range and measurement system.
viewing angle is measured at the center point of the LCD by CONOSCOPE(ergo-80).

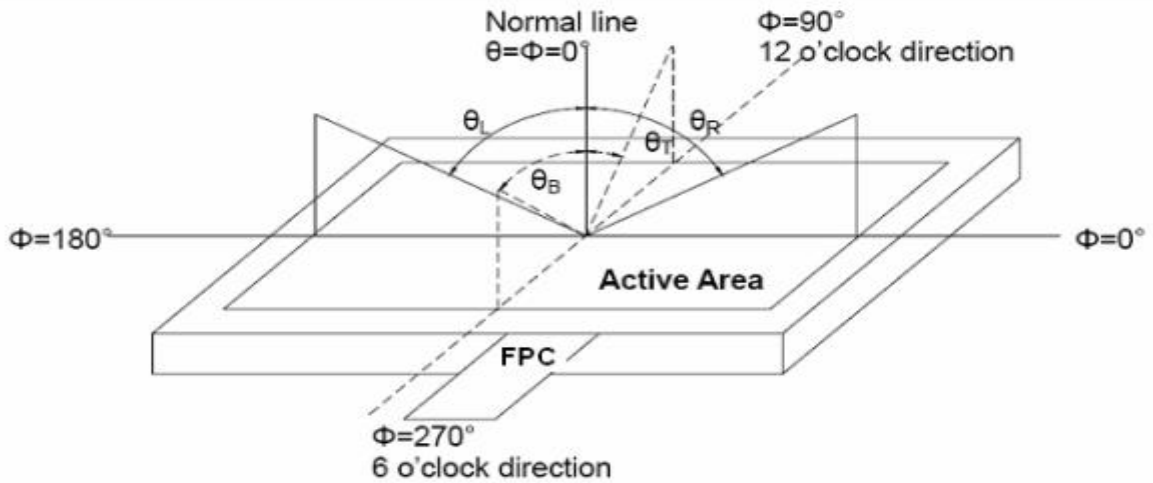

Fig 2 Definition of viewing angle

Note 3: Definition of contrast ratio

$$CR = \frac{\text{Luminance with all pixels white}}{\text{Luminance with all pixels black}}$$



Note 4: Definition of Response time

The response time is defined as the LCD optical switching time interval between “White” state and “Black” state. Rise time (T_{ON}) is the time between photo detector output intensity changed from 90% to 10%. And fall time (T_{OFF}) is the time between photo detector output intensity changed from 10% to 90%.

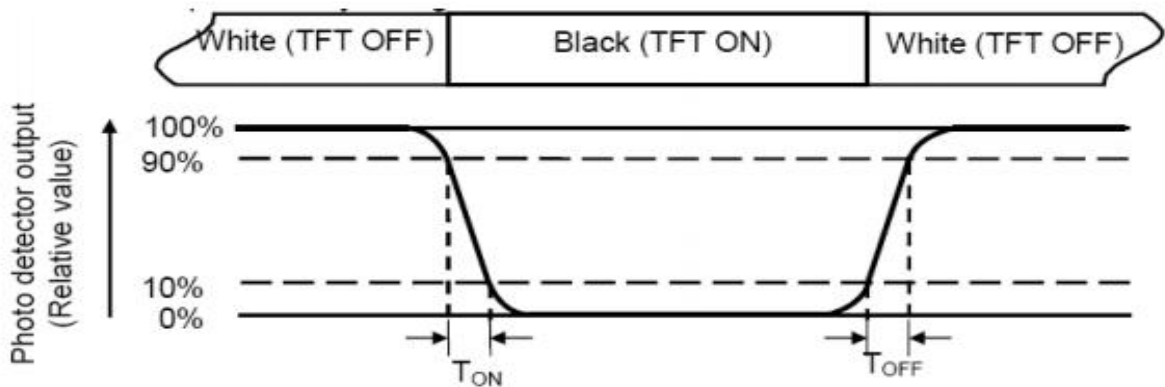

Note 5: Definition of color chromaticity (CIE1931)

Color coordinates measured at center point of LCD.

Note 6: Definition of Luminance Uniformity

The luminance uniformity in surface luminance is determined by measuring luminance at each test position 1 through n, and then dividing the maximum luminance of n points luminance by minimum luminance of n points luminance. For more information see FIG.3-a/b

Note 7: Surface luminance is the luminance with all pixels displaying white.

L_v = Average Surface Luminance with all white pixels ($P_1, P_2, P_3, \dots, P_n$)

For more information see FIG.3-a/b

Note 8: Size : $S \leq 5''$ (see Figure a) A : 5 mm B : 5 mm. H, V : Active area

Light spot size $\varnothing = 5\text{mm}$ (BM-5) or $\varnothing = 7.7\text{mm}$ (BM-7) 50cm distance or test spot position : see Figure a.

measurement instrument : TOPCON's luminance meter SR-3A or BM-7 or compatible (see Figure 1).

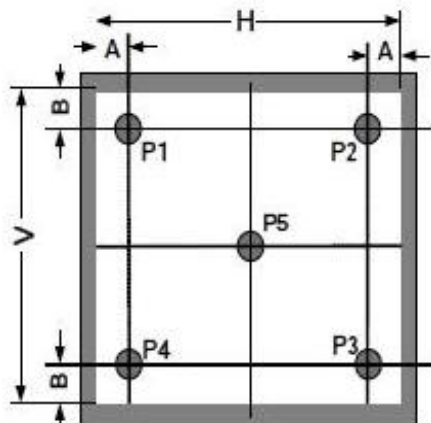

Fig. 3-a Definition of points



$5'' < S \leq 12.3''$ (see Figure b) . H,V : Active area

Light spot size $\varnothing = 5\text{mm}$ (BM-5) or $\varnothing = 7.7\text{mm}$ (BM-7) 50cm distance or compatible distance from the LCD surface to detector lens. test spot position : see Figure b.

measurement instrument : TOPCON's luminance meter SR-3A or BM-7 or compatible (see Figure 1).

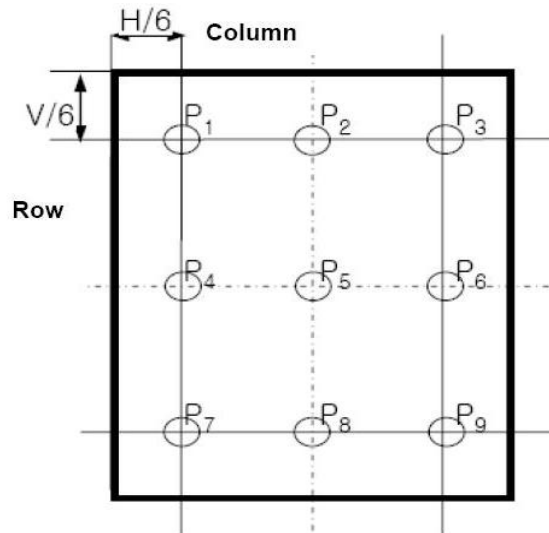

Fig. 3-b Definition of points



7. Reliability Test Items

Test Item	Test Conditions
High Temperature Storage	Ta= +85°C 240hrs
Low Temperature Storage	Ta= -30°C 240hrs
High Temperature Operation	Ta= +85°C 240hrs
Low Temperature Operation	Ta= -30°C 240hrs
High Temperature and Humidity Storage	Ta= +60°C, 90% RH 240hrs
Thermal Shock (Non-operation)	-30°C/30 min ~ +85°C/30 min for 20 cycles Start with cold temperature end with high temperature
Electro Static Discharge	Contact = ± 8 kV, class B Air = ±15 kV, class B R=330Ω,C=150pF
Vibration	Sweep: 10Hz~55Hz~10Hz Stroke: 1.5mm 2 hrs for each direction of X .Y. Z.
Mechanical Shock	60G 6ms,±X,±Y,±Z 3 times for each direction
Package Drop Test	Height: 60 cm 1 corner, 3 edges, 6 surfaces

Notes: The test result shall be evaluated after the sample has been left at room temperature and humidity for 2 hours without load. No condensation shall be accepted. The sample will not be accepted if appear these defects:

- 1). Air bubble in the LCD
- 2). Seal leak or Glass crack
- 3). Non display or abnormal display
- 4). Brightness reduction >50%



8. Mechanical Drawing

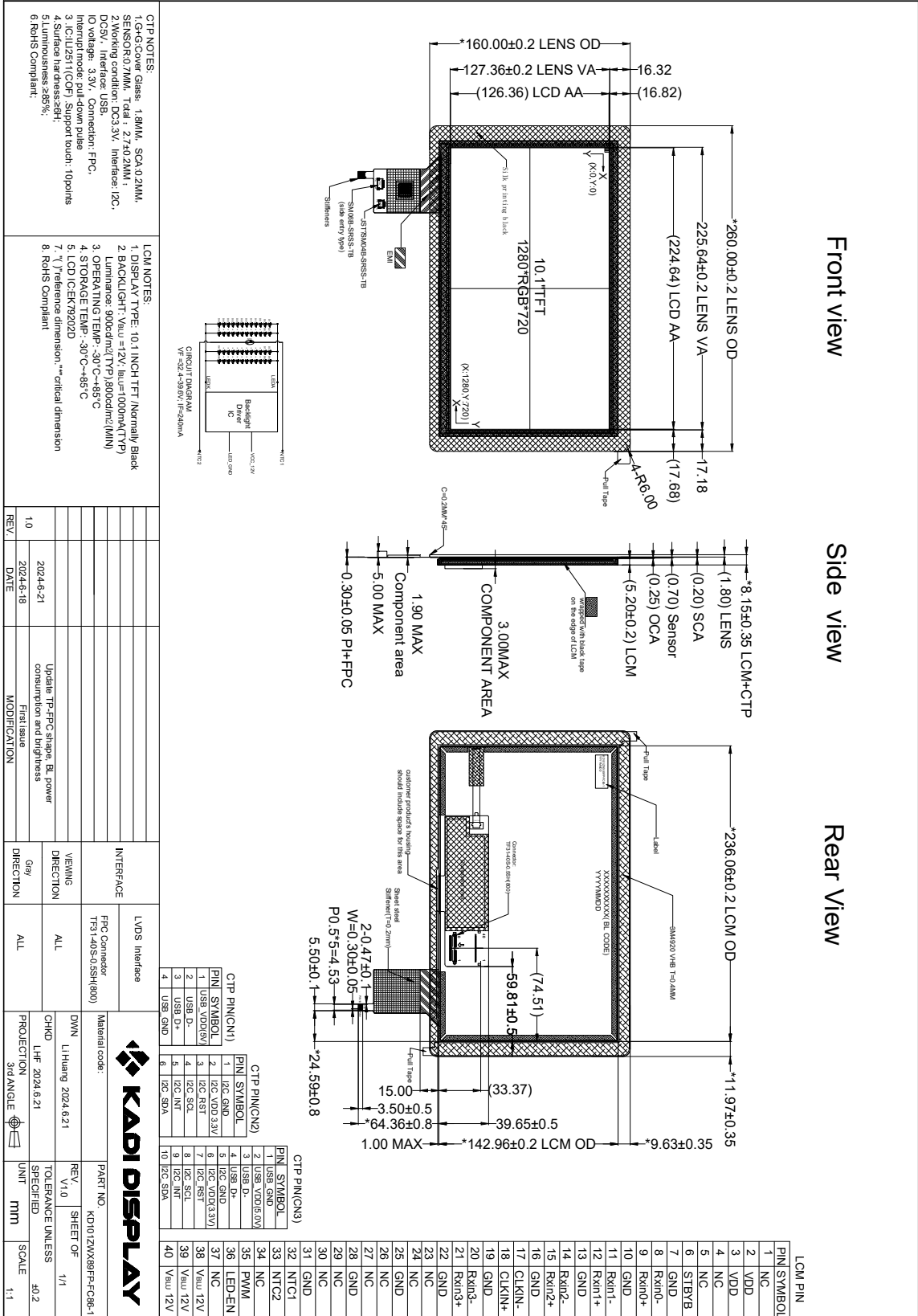



9. Packing

Packing Method

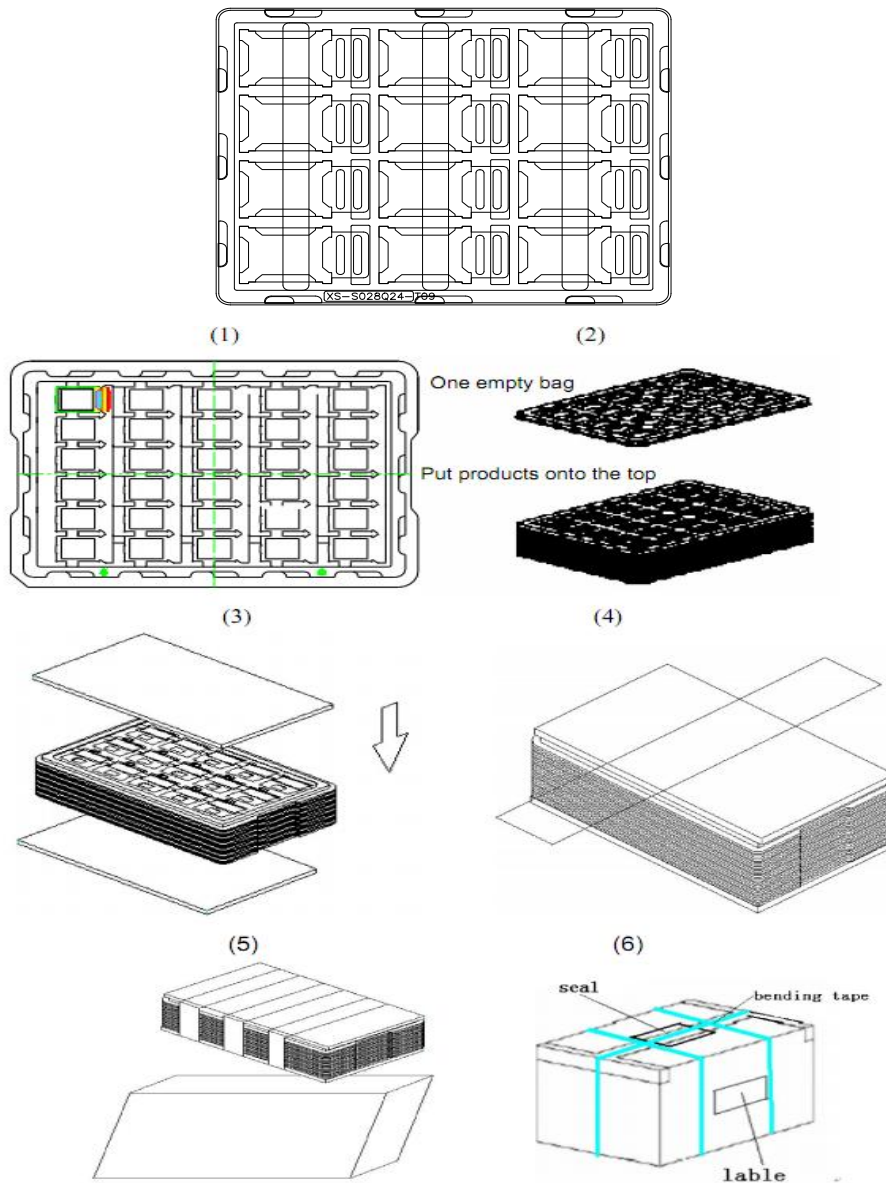

Steps:

1. Put module into tray cavity
2. Tray stacking
3. Put 1 cardboard under the tray stack and 1 cardboard above
4. Fix the cardboard to the tray stack with adhesive tape
5. Put the tray stack into carton
6. Carton sealing with adhesive tape



10. Precautions for Use of LCD modules

10.1 Handling Precautions

10.1.1. The display panel is made of glass. Do not subject it to a mechanical shock by dropping it from a high place, etc.

10.1.2. If the display panel is damaged and the liquid crystal substance inside it leaks out, be sure not to get any in your mouth, if the substance comes into contact with your skin or clothes, promptly wash it off using soap and water.

10.1.3. Do not apply excessive force to the display surface or the adjoining areas since this may cause the color tone to vary.

10.1.4. The polarizer covering the display surface of the LCD module is soft and easily scratched. Handle this polarizer carefully.

10.1.5. If the display surface is contaminated, breathe on the surface and gently wipe it with a soft dry cloth. If still not completely clear, moisten cloth with one of the following solvents:

- Isopropyl alcohol
- Ethyl alcohol

Solvents other than those mentioned above may damage the polarizer. Especially, do not use the following:

- Water
- Ketene
- Aromatic solvents

10.1.6. Do not attempt to disassemble the LCD Module.

10.1.7. If the logic circuit power is off, do not apply the input signals.

10.1.8. To prevent destruction of the elements by static electricity, be careful to maintain an optimum work environment.

10.1.8.1. Be sure to ground the body when handling the LCD Modules.

10.1.8.2. Tools required for assembly, such as soldering irons, must be properly ground.

10.1.8.3. To reduce the amount of static electricity generated, do not conduct assembly and other work under dry conditions.

10.1.8.4. The LCD Module is coated with a film to protect the display surface. Be care when peeling off this protective film since static electricity may be generated.

10.2 Storage Precautions

10.2.1. When storing the LCD modules, avoid exposure to direct sunlight or to the light of fluorescent lamps.

10.2.2. The LCD modules should be stored under the storage temperature range if the LCD modules will be stored for a long time, the recommend condition is :

Temperature : 0°C ~40°C Relatively humidity: ≤80%

10.2.3. The LCD modules should be stored in the room without acid, alkali and harmful gas.

10.3 Transportation Precautions

The LCD modules should be no falling and violent shocking during transportation, and also should avoid excessive press, water, damp and sunshine.