



PRODUCT SPECIFICATION

KADI Model: KD123BWU09NP

CUSTOMER Model: -

Description: 12.3" TFT-LCD Module

Version: 1.0

KADI	PREPARED BY	CHECKED BY	APPROVED BY
SIGNATURE			
DATE	2022.8.8	2022.8.8	2022.8.8

CUSTOMER APPROVAL	SIGNATURE	DATE



Record of Revisions

Version	Revise Date	Description	Page
1.0	2022-08-08	First Release	-



Contents

1. General Specifications	4
2. Absolute Maximum Ratings	4
3. Electrical Characteristics	5
4. Interface Pin Assignment	6
5. Interface Characteristics	8
6. Optical Specifications	15
7. Reliability Test Items	18
8. Mechanical Drawing	19
9. Packing	20
10. TFT-LCD Module Inspection Criteria	21
11. Precautions for Use of LCD modules	25



1. General Specifications

1.1 LCM General Information

Item	Specification	Unit
LCD Size	12.3	inch
Number of Pixels	1920(H) RGB x 720(V)	pixels
Display Mode	Normally Black	-
Viewing Direction	Free	o' clock
Interface	LVDS	-
Display Colors	16.7M	colors
Outline Dimension	299.43(H) x 119.96(V) x 2.9(D)	mm
Active Area	292.03(H) x 109.51(V)	mm
Pixel Pitch	0.1521(H) x 0.1521(V)	mm
Driver IC	TBD	-
Operation Temperature	-20~70	°C
Storage Temperature	-30~80	°C

Note1:Requirements on environmental protection RoHS compliant.

2. Absolute Maximum Ratings

Item	Symbol	MIN.	MAX.	Unit	Note
Analog Supply voltage	VDD	0	3.6	V	Note 1

Note 1:Permanent damage may occur to the LCD module if beyond this specification.

Functional operation should be restricted to the conditions described under normal operating conditions.

3. Electrical Characteristics

3.1 Recommended Operating Condition for TFT LCD

Item	Symbol	Min.	Typ.	Max.	Unit	Note
Analog Supply voltage	VDD	3.0	3.3	3.6	V	
Analog supply current	I _{VDD}	-	TBD	-	mA	VDD=3.3V
Logic input voltage	V _{IH}	0.7*VDD	-	VDD	V	
	V _{IL}	GND	-	0.3*VDD	V	

3.2 Recommended Driving Condition for Backlight

Item	Symbol	Min.	Typ.	Max.	Unit	Note
Driving Current	I _F	-	168	-	mA	
Driving Voltage	V _F	18.9	-	22.4	V	
Power consumption	W _{BL}	3.17	-	3.76	W	
LED Life-Time	N/A	30,000	-	-	Hours	Ta=25°C Note 1

Note 1: LED lifetime is defined as the module brightness decay 50% of original brightness at Ta=25 degree, typical current.

Note 2: LED circuit :

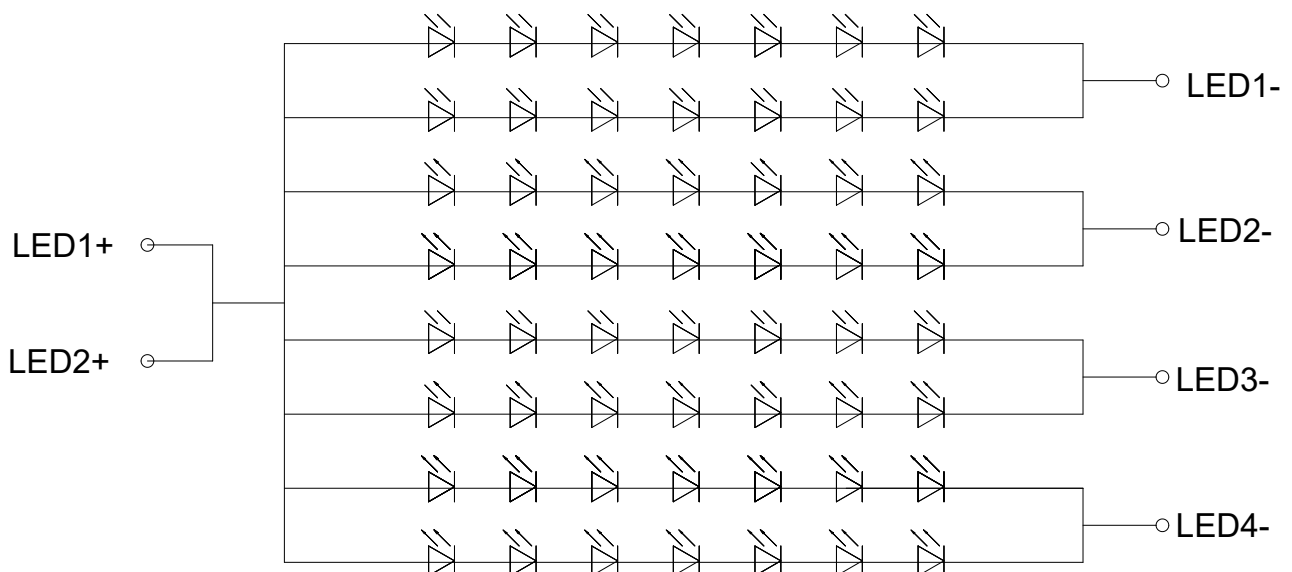

4. Interface Pin Assignment

4.1 LCM Pin Assignment

LCD Module connector: PF050-L60B-C21 manufactured by HIROSE

No.	Symbol	Description
1	GND	GROUND
2	NC	No connection
3	LED_A1	LED Anode1
4	LED_A2	LED Anode2
5	NC	No connection
6	LED_K1	LED Cathode 1
7	LED_K2	LED Cathode 2
8	LED_K3	LED Cathode 3
9	LED_K4	LED Cathode 4
10	NC(NTC1)	No connection(NTC1)
11	NC(NTC2)	No connection(NTC2)
12	NC	No connection
13	VDD	LCD Power Supply, Min. 3.0V/Typ. 3.3V/Max. 3.6V
14	VDD	LCD Power Supply, Min. 3.0V/Typ. 3.3V/Max. 3.6V
15	VCC_TP(NC)	No connection
16	NC	No connection
17	TP_INT(NC)	No connection
18	TP_I2C_SCL(NC)	No connection
19	TP_I2C_SDA(NC)	No connection
20	TP_RST(NC)	No connection
21	GND	GROUND
22	STBYB	Standby mode , Default H
23	Fail_det	Fail detect function output pin , Default H
24	UD	UP= H(Default), U2D sequence UP= L, D2U sequence
25	RESET	LCD reset , Default H
26	BIST_EN	Enable BIST function,GND for Normal , Default L
27	LR	LR= 0, shift left LR= 1(Default), shift right



28	DISP_I2C_SDA	Display I2C DATA
29	DISP_I2C_SCL	Display I2C CLOCK
30	GND	GROUND
31	DA_N_E	Negative Transmission data of Pixel 0 (EVEN)
32	DA_P_E	Positive Transmission data of Pixel 0 (EVEN)
33	GND	GROUND
34	DB_N_E	Negative Transmission data of Pixel 1 (EVEN)
35	DB_P_E	Positive Transmission data of Pixel 1 (EVEN)
36	GND	GROUND
37	DC_N_E	Negative Transmission data of Pixel 2 (EVEN)
38	DC_P_E	Positive Transmission data of Pixel 2 (EVEN)
39	GND	GROUND
40	DCLK_N_E	Negative Transmission Clock (EVEN)
41	DCLK_P_E	Positive Transmission Clock (EVEN)
42	GND	GROUND
43	DD_N_E	Negative Transmission data of Pixel 3 (EVEN)
44	DD_P_E	Positive Transmission data of Pixel 3 (EVEN)
45	GND	GROUND
46	DA_N_O	Negative Transmission data of Pixel 0 (ODD)
47	DA_P_O	Positive Transmission data of Pixel 0 (ODD)
48	GND	GROUND
49	DB_N_O	Negative Transmission data of Pixel 1 (ODD)
50	DB_P_O	Positive Transmission data of Pixel 1 (ODD)
51	GND	GROUND
52	DC_N_O	Negative Transmission data of Pixel 2 (ODD)
53	DC_P_O	Positive Transmission data of Pixel 2 (ODD)
54	GND	GROUND
55	DCLK_N_O	Negative Transmission Clock (ODD)
56	DCLK_P_O	Positive Transmission Clock (ODD)
57	GND	GROUND
58	DD_N_O	Negative Transmission data of Pixel 3 (ODD)
59	DD_P_O	Positive Transmission data of Pixel 3 (ODD)
60	GND	GROUND

5. Interface Characteristics

5.1 LVDS Interface

- LVDS Receiver : Timing Controller (LVDS Rx merged) / LVDS Data : Pixel Data

< Table 7. LVDS Input Data Mapping >

Channel No.	Data No.	8-bit LVDS Type
		VESA
0	Bit-0	R0
	Bit-1	R1
	Bit-2	R2
	Bit-3	R3
	Bit-4	R4
	Bit-5	R5
	Bit-6	G0
1	Bit-0	G1
	Bit-1	G2
	Bit-2	G3
	Bit-3	G4
	Bit-4	G5
	Bit-5	B0
	Bit-6	B1
2	Bit-0	B2
	Bit-1	B3
	Bit-2	B4
	Bit-3	B5
	Bit-4	HS
	Bit-5	VS
	Bit-6	DE
3	Bit-0	R6
	Bit-1	R7
	Bit-2	G6
	Bit-3	G7
	Bit-4	B6
	Bit-5	B7
	Bit-6	-

5.2 LVDS Rx Interface Timing Parameter

The specification of the LVDS Rx interface timing parameter is shown in Table 8

<Table 8. LVDS Rx Interface Timing Specification>

Item	Symbol	Min	Typ	Max	Unit	Remark
CLKIN Period	tRCP	10	T	40	nsec	
Receiver Data Input Margin	tRMG	TBD	-	TBD	nsec	fCLKIN=MHz
		TBD	-	TBD	nsec	fCLKIN=MHz
Input Data 0	tRIP1	- tRMG	0.0	tRMG	Clock	
Input Data 1	tRIP0	T/7- tRMG	T/7	T/7+ tRMG	Clock	
Input Data 2	tRIP6	2 T/7- tRMG	2T/7	2T/7+ tRMG	Clock	
Input Data 3	tRIP5	3T/7- tRMG	3T/7	3T/7+ tRMG	Clock	
Input Data 4	tRIP4	4T/7- tRMG	4T/7	4T/7+ tRMG	Clock	
Input Data 5	tRIP3	5T/7- tRMG	5T/7	5T/7+ tRMG	Clock	
Input Data 6	tRIP2	6T/7- tRMG	6T/7	6T/7+ tRMG	Clock	

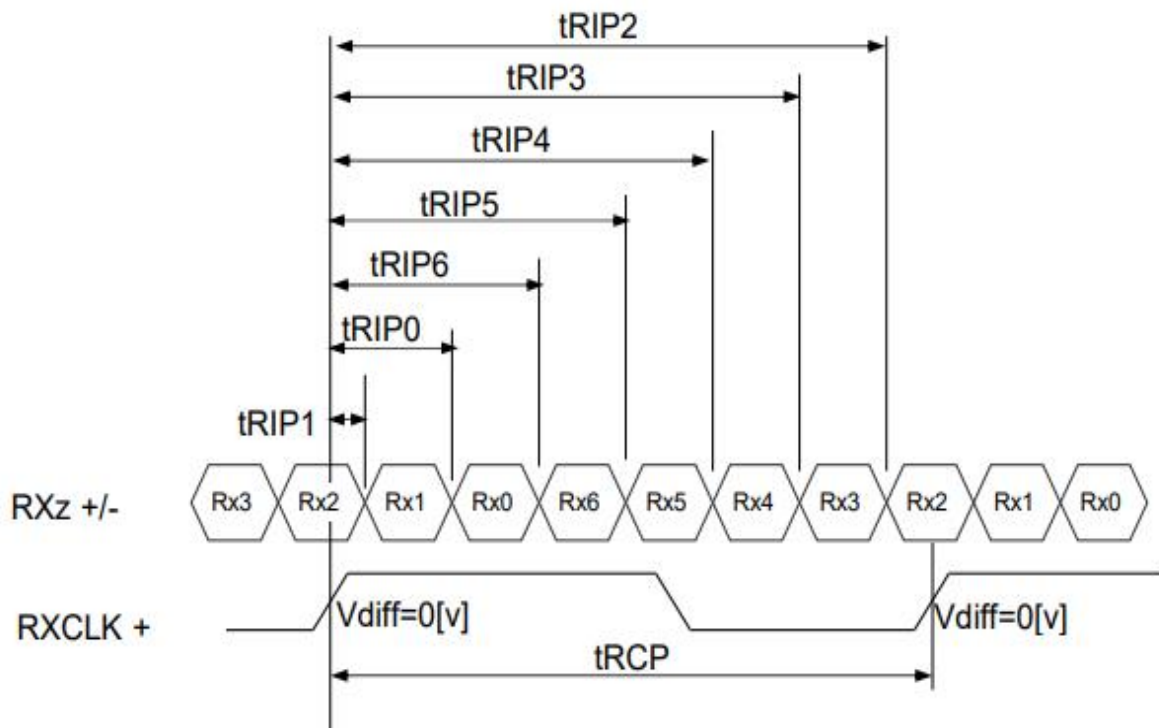

* Vdiff = (RXz+)-(RXz-),.....,(RXCLK+)-(RXCLK-)

5.3 DC Specification

- LVDS Receiver Differential Input (DC Characteristics)

< Table 9-1. LVDS Rx DC Characteristics >

Parameter	Symbol	Min	Typ	Max	Unit	Notes
Differential Input High Threshold Voltage	V_{TH}	-	-	+100	mV	VCM=1.2V
Differential Input Low Threshold Voltage	V_{TL}	-100	-	-	mV	
Differential Input Common Mode Voltage	VCM	0.7	1.2	1.6	V	
Differential Input Voltage	$ V_{ID} $	100	-	600	mV	

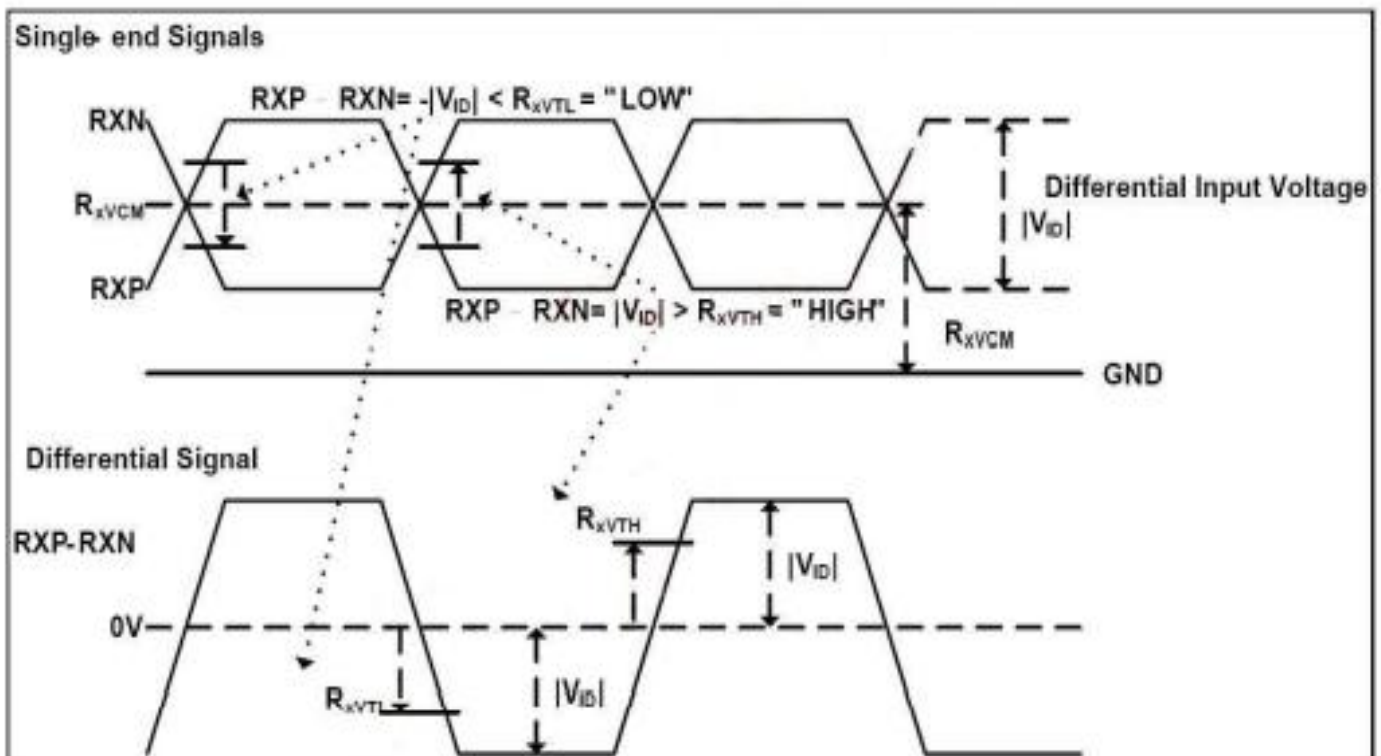

5.4 AC Specification

- LVDS Receiver Differential Input (AC Characteristics)

< Table 9-2. LVDS Rx AC Characteristics >

Parameter	Symbol	Min	Typ	Max	Unit	Notes
LVDS Strobe Width	t_{SW}	TBD	-	-	ps	V _{cm} =1.2V VID = 400mV @65MHz
LVDS Receiver Skew Margin	t_{RSM}	TBD	-	-	ps	

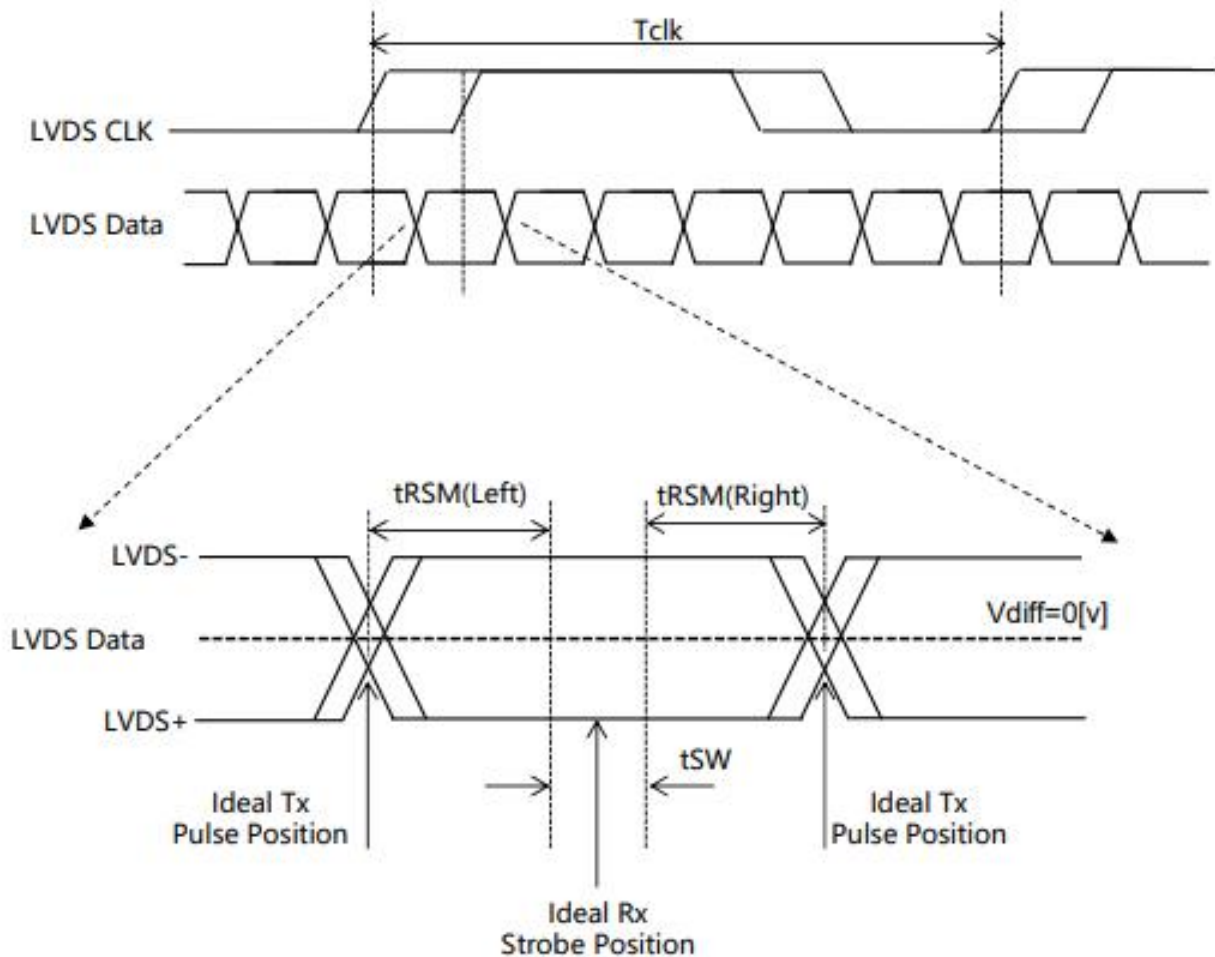

Note:

RSM: Receiver Skew Margin

SW: Strobe Width (Setup and Hold time; TCON Internal data sampling window)

5.5 Interface timing Parameter

5.5.1 Timing Parameters (DE only mode)

< Table7. Timing Parameter >

Item		Symbol	min	typ	max	UNIT	
LCD	Frame Rate	-	60			Hz	
	Pixels Rate	-	44.8	46.06	49.8	MHz	
Timing	Horizontal	Total time	tHP	1008	1010	1056	t _{CLK}
		Active time	tHadr	960			t _{CLK}
		Blanking time	tHBP+ tHFP+tHsync	48	50	96	t _{CLK} t _{CLK}
	Vertical	Total time	tvp	740	760	786	t _H
		Active time	tVadr	720			t _H
		Blanking time	tVBP+ tVFP+tVsync	20	40	66	t _H t _H
Port			-	2	-	Port	

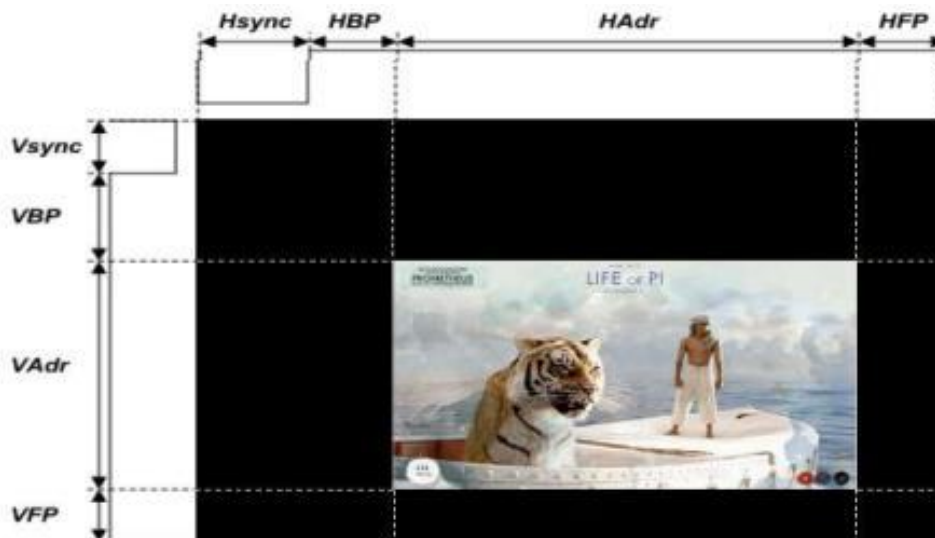

Note

1. DE Only Mode, While operation, DE signal should be have the same cycle. The input of HSYNC & VSYNC signal does not have an effect on normal operation.
2. Best operation clock frequency is 46.06Mhz.
3. Frequency = [H Total] * [V Total] * [vertical Frame rate]
H Total, V Total and Frame rate]should operate within the range between Frequency_Min and Frequency_Max
4. Except Best operation clock frequency, FOS(Flicker & Brightness & Crosstalk, Etc.) are not guaranteed.
5. Main frequency Max is 49.8Mhz MHz without spread spectrum



5.5.2 Input Signals, Basic Display Colors and Gray Scale of Colors

< Table 12. Input Signal and Display Color Table >

Color & Gray Scale		Input Data Signal																							
		Red Data								Green Data								Blue Data							
		R7	R6	R5	R4	R3	R2	R1	R0	G7	G6	G5	G4	G3	G2	G1	G0	B7	B6	B5	B4	B3	B2	B1	B0
Basic Colors	Black	0	0	0	0	0	0	0	0	0	0	0	0	0	0	0	0	0	0	0	0	0	0	0	
	Blue	0	0	0	0	0	0	0	0	0	0	0	0	0	0	0	0	1	1	1	1	1	1	1	1
	Green	0	0	0	0	0	0	0	0	1	1	1	1	1	1	1	1	0	0	0	0	0	0	0	0
	Cyan	0	0	0	0	0	0	0	0	1	1	1	1	1	1	1	1	1	1	1	1	1	1	1	1
	Red	1	1	1	1	1	1	1	1	0	0	0	0	0	0	0	0	0	0	0	0	0	0	0	0
	Magenta	1	1	1	1	1	1	1	1	0	0	0	0	0	0	0	0	1	1	1	1	1	1	1	1
	Yellow	1	1	1	1	1	1	1	1	1	1	1	1	1	1	1	1	0	0	0	0	0	0	0	0
	White	1	1	1	1	1	1	1	1	1	1	1	1	1	1	1	1	1	1	1	1	1	1	1	1
Gray Scale of Red	Black	0	0	0	0	0	0	0	0	0	0	0	0	0	0	0	0	0	0	0	0	0	0	0	
	△	0	0	0	0	0	0	0	1	0	0	0	0	0	0	0	0	0	0	0	0	0	0	0	
	Darker	0	0	0	0	0	0	1	0	0	0	0	0	0	0	0	0	0	0	0	0	0	0	0	
	△																								
	▽																								
	Brighter	1	1	1	1	1	1	0	1	0	0	0	0	0	0	0	0	0	0	0	0	0	0	0	
	▽	1	1	1	1	1	1	1	0	0	0	0	0	0	0	0	0	0	0	0	0	0	0	0	
	Red	1	1	1	1	1	1	1	1	0	0	0	0	0	0	0	0	0	0	0	0	0	0	0	0
Gray Scale of Green	Black	0	0	0	0	0	0	0	0	0	0	0	0	0	0	0	0	0	0	0	0	0	0	0	
	△	0	0	0	0	0	0	0	0	0	0	0	0	0	0	0	1	0	0	0	0	0	0	0	
	Darker	0	0	0	0	0	0	0	0	0	0	0	0	0	0	1	0	0	0	0	0	0	0	0	
	△																								
	▽																								
	Brighter	0	0	0	0	0	0	0	0	1	1	1	1	1	1	0	1	0	0	0	0	0	0	0	
	▽	0	0	0	0	0	0	0	0	1	1	1	1	1	1	1	0	0	0	0	0	0	0	0	
	Green	0	0	0	0	0	0	0	0	1	1	1	1	1	1	1	1	0	0	0	0	0	0	0	0
Gray Scale of Blue	Black	0	0	0	0	0	0	0	0	0	0	0	0	0	0	0	0	0	0	0	0	0	0	0	
	△	0	0	0	0	0	0	0	0	0	0	0	0	0	0	0	0	0	0	0	0	0	0	1	
	Darker	0	0	0	0	0	0	0	0	0	0	0	0	0	0	0	0	0	0	0	0	0	0	1	
	△																								
	▽																								
	Brighter	0	0	0	0	0	0	0	0	0	0	0	0	0	0	0	0	1	1	1	1	1	1	0	
	▽	0	0	0	0	0	0	0	0	0	0	0	0	0	0	0	0	1	1	1	1	1	1	0	
	Blue	0	0	0	0	0	0	0	0	0	0	0	0	0	0	0	0	1	1	1	1	1	1	1	
Gray Scale of White	Black	0	0	0	0	0	0	0	0	0	0	0	0	0	0	0	0	0	0	0	0	0	0	0	
	△	0	0	0	0	0	0	0	1	0	0	0	0	0	0	0	1	0	0	0	0	0	0	1	
	Darker	0	0	0	0	0	0	1	0	0	0	0	0	0	0	1	0	0	0	0	0	0	0	1	
	△																								
	▽																								
	Brighter	1	1	1	1	1	1	0	1	1	1	1	1	1	0	1	1	1	1	1	1	1	0	1	
	▽	1	1	1	1	1	1	1	0	1	1	1	1	1	1	0	1	1	1	1	1	1	1	0	
	White	1	1	1	1	1	1	1	1	1	1	1	1	1	1	1	1	1	1	1	1	1	1	1	

5.6 POWER SEQUENCE

To prevent a latch-up or DC operation of the Open Cell, the power on/off sequence shall be as shown in below.

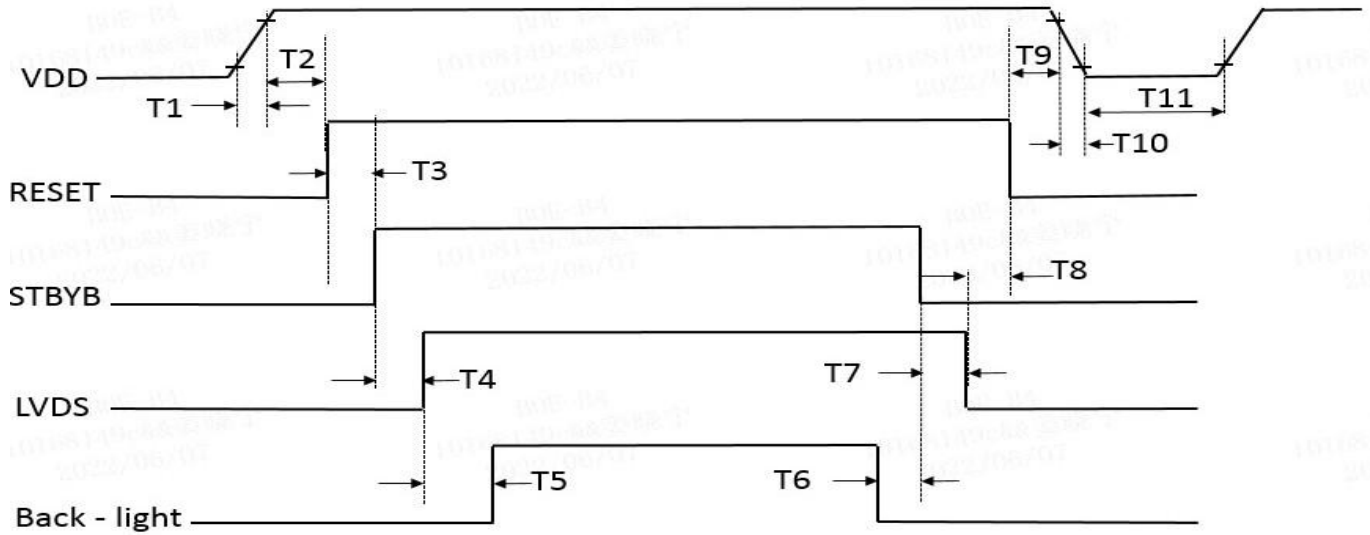

Parameter	Values			Units
	Min	Typ	Max	
T1	0.5	-	10	ms
T2	20	-	-	ms
T3	1	-	-	ms
T4	0	-	50	ms
T5	200	-	-	ms
T6	200	-	-	ms
T7	0	-	50	ms
T8	100	-	-	ms
T9	0	-	-	ms
T10	0.5	-	10	ms
T11	1000	-	-	ms

6. Optical Specifications

Item	Symbol	Condition	Min.	Typ.	Max.	Unit	Note
Viewing Angle (CR≥10) B/L ON	θ_T	$\Phi=90^\circ$ (12 o'clock)	80	89	-	deg	Note2
	θ_B	$\Phi=270^\circ$ (6 o'clock)	80	89	-	deg	Note2
	θ_L	$\Phi=180^\circ$ (9 o'clock)	80	89	-	deg	Note2
	θ_R	$\Phi=0^\circ$ (3 o'clock)	80	89	-	deg	Note2
Response Time	T_{ON}	Normal $\theta=\Phi=0^\circ$	-	15	17	msec	Note4
	T_{OFF}		-	15	17	msec	Note4
Contrast Ratio	CR		900	1200	-	-	Note1 Note3
Color Chromaticity	W_X		0.283	0.313	0.343	-	Note1 Note5
	W_Y		0.299	0.329	0.359	-	Note1 Note5
Luminance	L		320	400	-	cd/m ²	Note1 Note7
Luminance Uniformity	Y_U		75	-	-	%	Note1 Note6
NTSC	-		67	72	-	%	-

Note 1:Definition of optical measurement system

The optical characteristics should be measured in dark room. After 5 minutes operation, the optical properties are measured at the center point of the LCD screen. All input terminals LCD panel must be ground when measuring the center area of the panel.

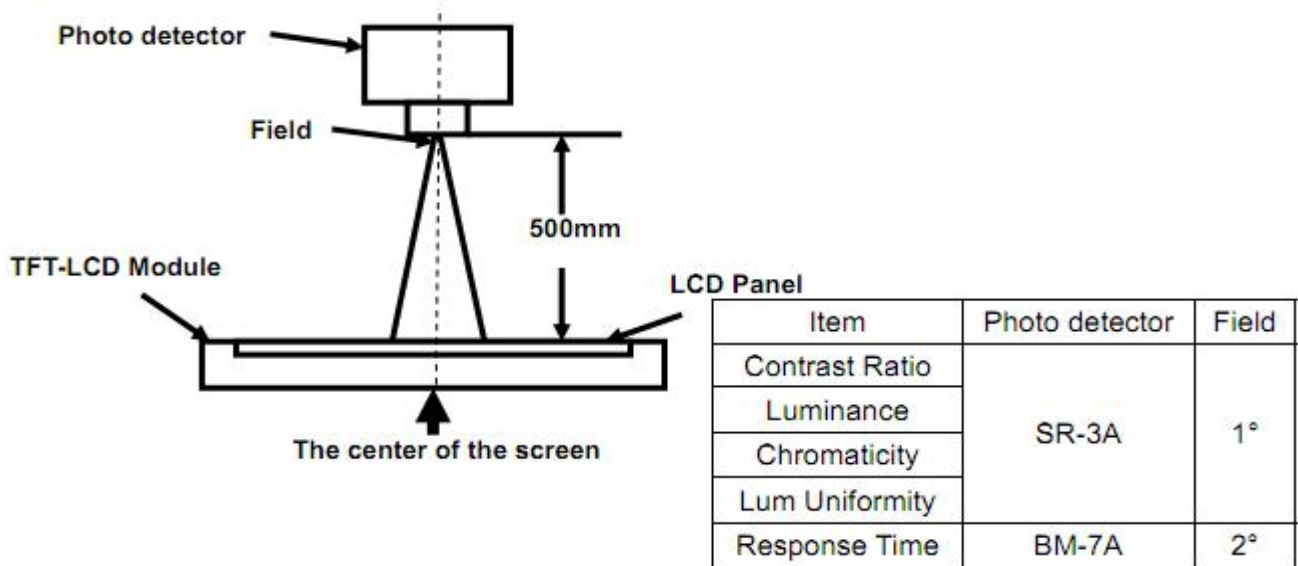

Note 2: Definition of viewing angle range and measurement system

Viewing angle is measured at the center point of the LCD by CONOSCOPE(ergo-80).

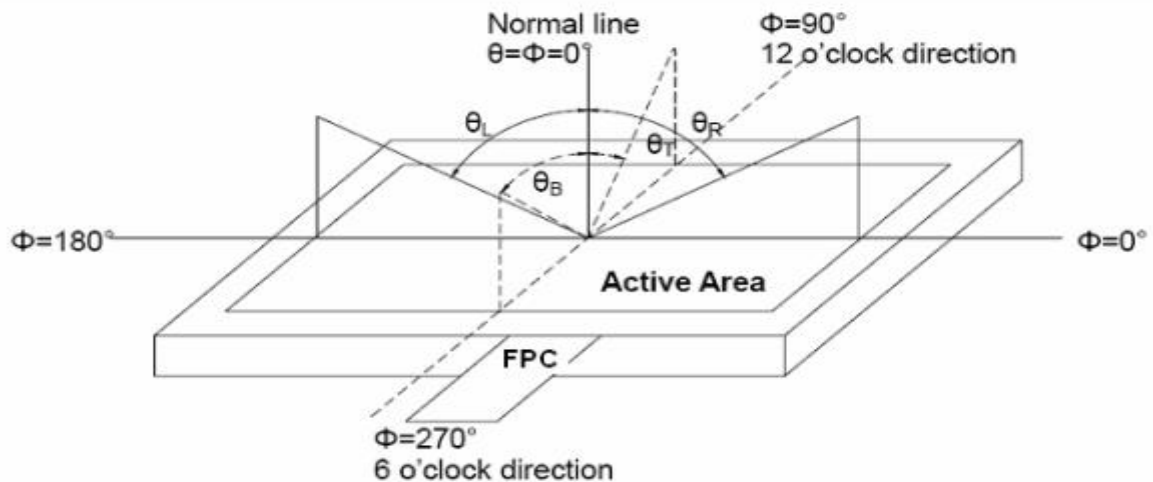

Fig. 1 Definition of viewing angle

Note 3: Definition of contrast ratio

$$CR = \frac{\text{Luminance with all pixels white}}{\text{Luminance with all pixels black}}$$

Note 4: Definition of Response time

The response time is defined as the LCD optical switching time interval between “White” state and “Black”state. Rise time (TON) is the time between photo detector output intensity changed from 90% to 10%. And fall time (TOFF) is the time between photo detector output intensity changed from 10% to 90%.

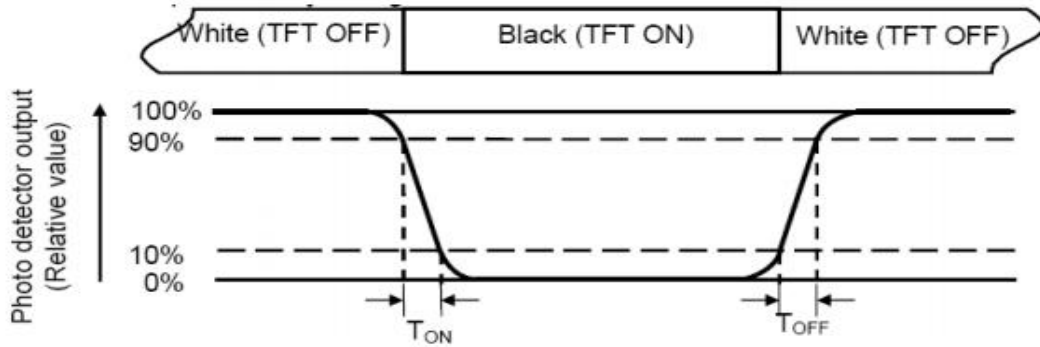

Note 5: Definition of color chromaticity (CIE1931)

Color coordinates measured at center point of LCD.

Note 6: Definition of Luminance Uniformity

The luminance uniformity in surface luminance is determined by measuring luminance at each test position 1 through n, and then dividing the maximum luminance of n points luminance by minimum luminance of n points luminance. For more information see FIG.2.

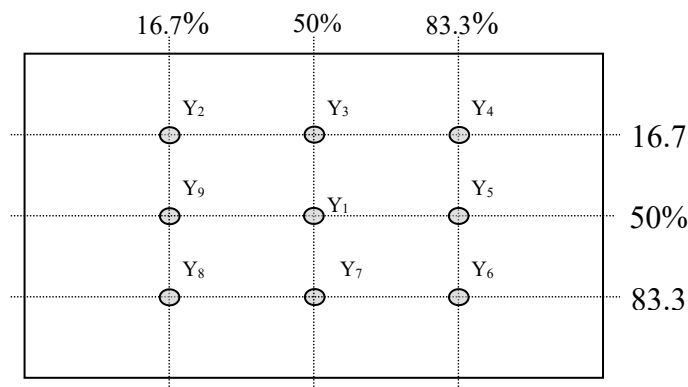

Fig. 2 Definition of points

Note 7: Definition of Luminance (Refer Fig. 2)

Surface luminance is the luminance with all pixels displaying white.

L_v = Average Surface Luminance with all white pixels($P_1, P_2, P_3, \dots, P_n$).

7. Reliability Test Items

Test Item	Test Conditions
High Temperature Storage	Ta= +80℃ 96hrs
Low Temperature Storage	Ta= -30℃ 96hrs
High Temperature Operation	Ta= +70℃ 96hrs
Low Temperature Operation	Ta= -20℃ 96hrs
High Temperature and Humidity Storage	Ta= +60℃, 90% RH 96hrs
Thermal Shock (Non-operation)	-30℃/30 min ~ +80℃/30 min for 20 cycles Start with cold temperature end with high temperature
Electro Static Discharge	Contact = ± 4 kV, class B Air = ± 8 kV, class B R=330Ω,C=150pF
Vibration	Sweep: 10Hz~55Hz~10Hz Stroke: 1.5mm 2 hrs for each direction of X .Y. Z.
Mechanical Shock	60G 6ms,±X,±Y,±Z 3 times for each direction
Package Drop Test	Height: 60 cm 1 corner, 3 edges, 6 surfaces

Notes: The test result shall be evaluated after the sample has been left at room temperature and humidity for 2 hours without load. No condensation shall be accepted. The sample will not be accepted if appear these defects:

- 1). Air bubble in the LCD
- 2). Seal leak or Glass crack
- 3). Non display or abnormal display
- 4). Brightness reduction >50%

8. Mechanical Drawing

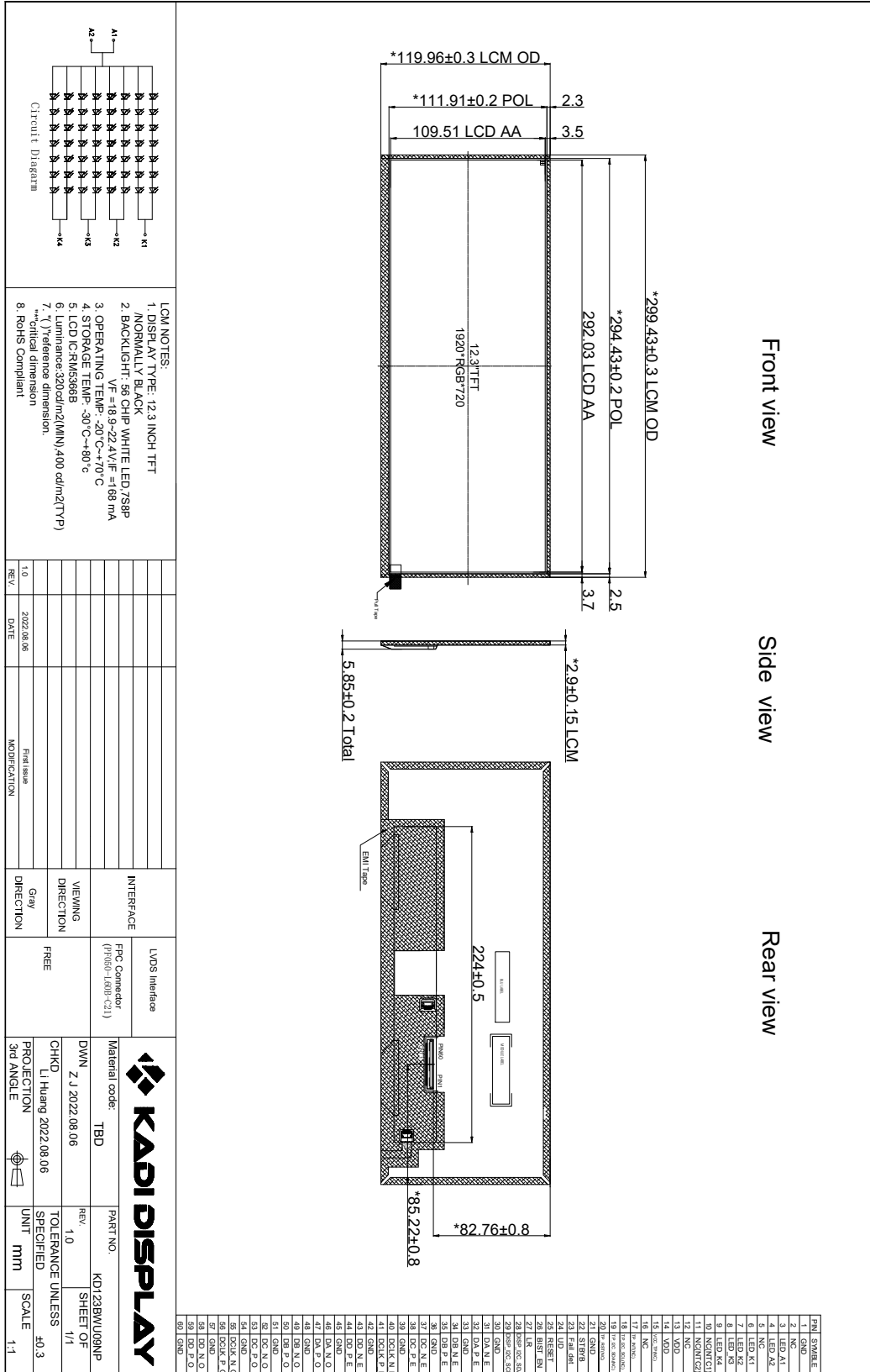

9. Packing

Packing Method

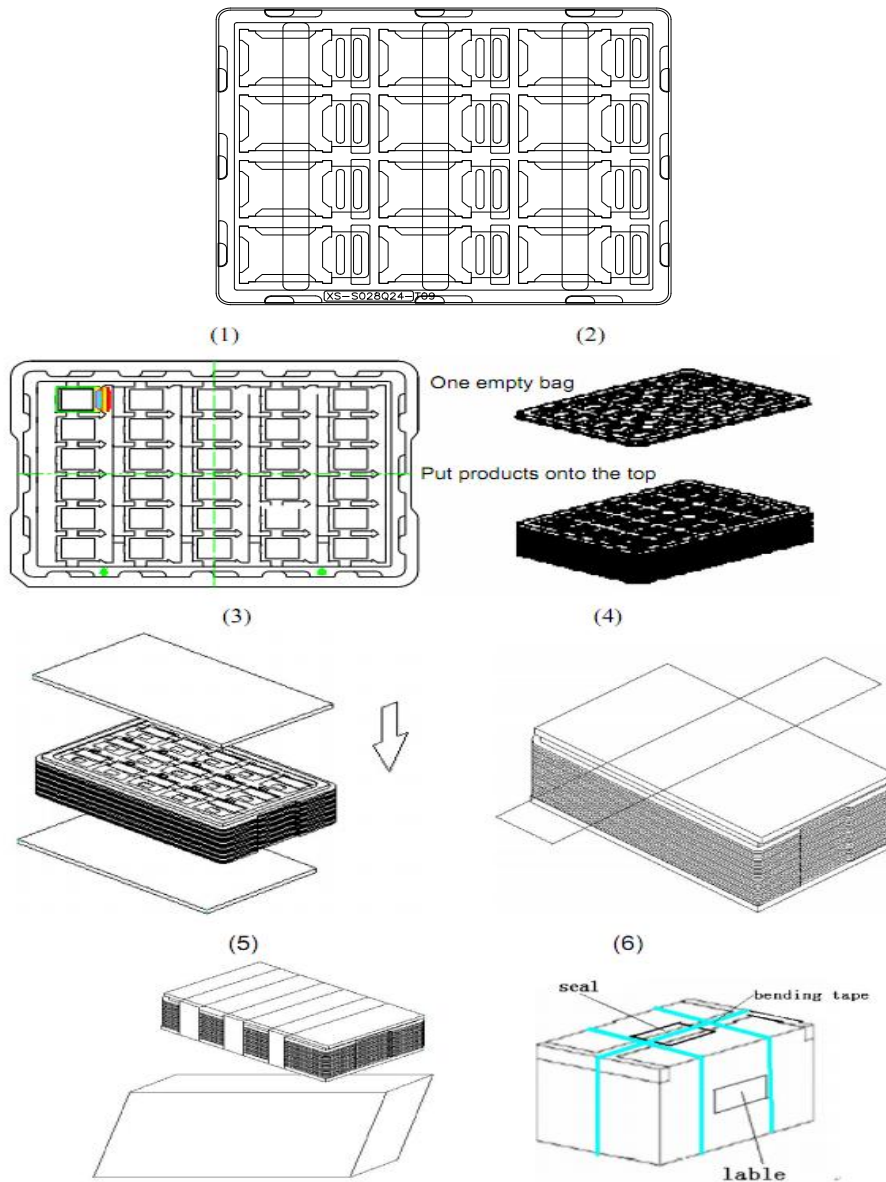

Steps:

1. Put module into tray cavity
2. Tray stacking
3. Put 1 cardboard under the tray stack and 1 cardboard above
4. Fix the cardboard to the tray stack with adhesive tape
5. Put the tray stack into carton
6. Carton sealing with adhesive tape

10. TFT-LCD Module Inspection Criteria

10.1 Scope

The incoming inspection standards shall be applied to TFT –LCD Modules (hereinafter called "Modules") that supplied by CDTech.

10.2 Incoming Inspection

The customer shall inspect the modules within twenty calendar days of the delivery date (the "inspection period") at its own cost. The result of the inspection (acceptance or rejection) shall be recorded in writing, and a copy of this writing will be promptly sent to the seller, If the results of the inspecting from buyer does not send to the seller within twenty calendar days of the delivery date. The modules shall be regards as acceptance. Should the customer fail to notify the seller within the inspection period, the buyers right to reject the modules shall be lapsed and the modules shall be deemed to have been accepted by the buyer.

10.3 Inspection Sampling

10.3.1. Lot size: Quantity per shipment lot per model

10.3.2. Sampling type: Normal inspection, Single sampling

10.3.3. Inspection level: II

10.3.4. Sampling table: MIL-STD-105E

10.3.5. Acceptable quality level (AQL)

Major defect: AQL=0.65

Minor defect: AQL=1.00

10.4 Inspection Conditions

10.4.1 Ambient conditions:

a. Temperature: Room temperature $25\pm 5^{\circ}\text{C}$

b. Humidity: $(60\pm 10)\% \text{RH}$

c. Illumination: Single fluorescent lamp non-directive (300 to 700 Lux)

10.4.2 Viewing distance

The distance between the LCD and the inspector's eyes shall be at least 35 ± 5 cm.

10.4.3 Viewing Angle

U/D: $45^{\circ}/45^{\circ}$, L/R: $45^{\circ}/45^{\circ}$

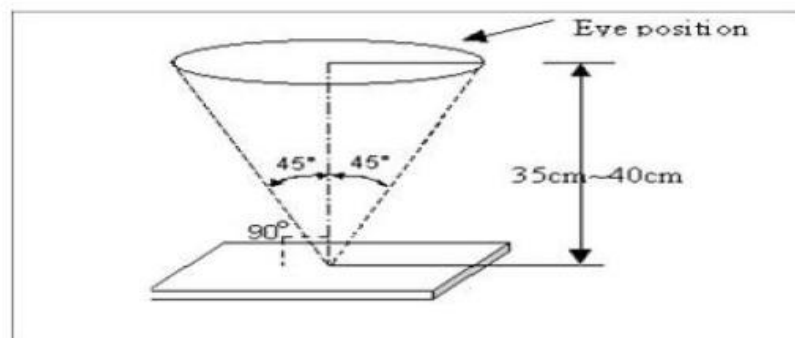

10.5 Inspection Criteria

Defects are classified as major defects and minor defects according to the degree of defectiveness defined here in.

10.5.1. Major defect

Item No	Items to be inspected	Inspection Standard
5.1.1	All functional defects	1) No display 2) Display abnormally 3) Short circuit 4) line defect
5.1.2	Missing	Missing function component
5.1.3	Crack	Glass Crack

10.5.2. Minor defect

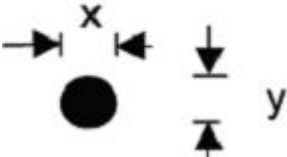
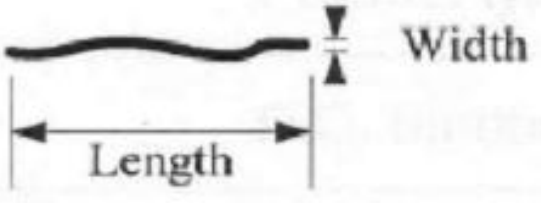
Item No	Items to be inspected	Inspection standard	
5.2.1	Spot Defect Including Black spot White spot Pinhole Foreign particle Polarizer dirt	For dark/white spot is defined : $\varphi = (x+y) / 2$ 	
		Size φ (mm)	Acceptable Quantity
		$\Phi < 0.2\text{mm}$	Ignore
		$0.2\text{mm} \leq \Phi \leq 0.4\text{mm}$	$N \leq 4$ $DS \geq 10\text{mm}$
		$\Phi > 0.4$	Not allowable
5.2.2	Line Defect Including Black line White line Scratch	Define: 	
		Width(mm) Length(mm)	Acceptable Quantity

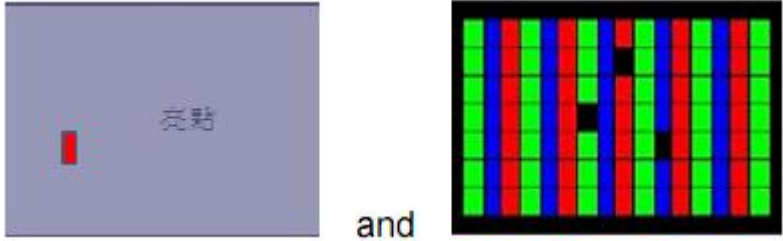
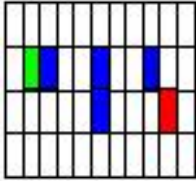
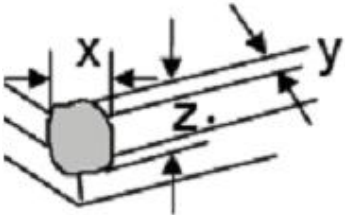
		$W \leq 0.05\text{mm}$	No count	
		$0.05\text{mm} < W \leq 0.1\text{mm}, L \leq 3\text{mm}$	N \leq 3	
		$W > 0.1\text{mm}, L > 2\text{mm}$	Not allowed	
5.2.3	Polarizer Dent/Bubble	Size ϕ (mm)	Acceptable Quantity	
		$\phi < 0.2\text{mm}$	Ignore	
		$0.2\text{mm} \leq \phi \leq 0.4\text{mm}$	N \leq 4 DS \geq 10mm	
		$\phi > 0.4$	Not allowed	
5.2.4	Electrical Dot Defect	Bright and Black dot define:		
				
		and		
				
		Two Adjacent Dot		
		Inspection pattern: Full white, Full black, Red, green and blue screens		
				Acceptable Quantity
Item		Single Dot	Adjacent 2dots	Total
Black dot defect		4	0	4
Bright dot defect		0	0	0
Total Dot				4
		1. Corner Fragment: 		
Size(mm)		Acceptable Quantity		

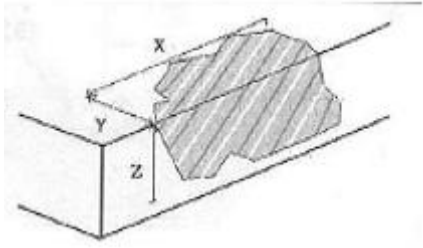
5.2.5	Glass defect	$X \leq 3$ $Y \leq 1$ $Z \leq T$	Ignore T: Glass thickness X: Length Y: Width Z: thickness
			
		2. Side Fragment:	
		Size(mm) $X \leq 5.0$ $Y \leq 1$ $Z \leq T$	Acceptable Quantity T: Glass thickness X: Length Y: Width Z: thickness

- Note:
- 1). Dot defect is defined as the defective area of the dot area is larger than 50% of the dot area.
 - 2). The distance between two bright dot defects (red, green, blue, and white) should be larger than 15mm.
 - 3). The distance between black dot defects or black and bright dot defects should be more than 5mm apart.
 - 4). Polarizer bubble is defined as the bubble appears on active display area. The defect of polarizer bubble shall be ignored if the polarizer bubble appears on the outside of active display area.

10.6 Mechanics specification

As for the outside dimension, weight of the modules, please refer to product specification for more details.

11. Precautions for Use of LCD modules

11.1 Handling Precautions

11.1.1. The display panel is made of glass. Do not subject it to a mechanical shock by dropping it from a high place, etc.

11.1.2. If the display panel is damaged and the liquid crystal substance inside it leaks out, be sure not to get any in your mouth, if the substance comes into contact with your skin or clothes, promptly wash it off using soap and water.

11.1.3. Do not apply excessive force to the display surface or the adjoining areas since this may cause the color tone to vary.

11.1.4. The polarizer covering the display surface of the LCD module is soft and easily scratched. Handle this polarizer carefully.

11.1.5. If the display surface is contaminated, breathe on the surface and gently wipe it with a soft dry cloth. If still not completely clear, moisten cloth with one of the following solvents:

- Isopropyl alcohol
- Ethyl alcohol

Solvents other than those mentioned above may damage the polarizer. Especially, do not use the following:

- Water
- Ketene
- Aromatic solvents

11.1.6. Do not attempt to disassemble the LCD Module.

11.1.7. If the logic circuit power is off, do not apply the input signals.

11.1.8. To prevent destruction of the elements by static electricity, be careful to maintain an optimum work environment.

11.1.8.1. Be sure to ground the body when handling the LCD Modules.

11.1.8.2. Tools required for assembly, such as soldering irons, must be properly ground.

11.1.8.3. To reduce the amount of static electricity generated, do not conduct assembly and other work under dry conditions.

11.1.8.4. The LCD Module is coated with a film to protect the display surface. Be care when peeling off this protective film since static electricity may be generated.

11.2 Storage Precautions

11.2.1. When storing the LCD modules, avoid exposure to direct sunlight or to the light of fluorescent lamps.

11.2.2. The LCD modules should be stored under the storage temperature range if the LCD modules will be stored for a long time, the recommend condition is :

Temperature : 0°C ~40°C Relatively humidity: ≤80%

11.2.3. The LCD modules should be stored in the room without acid, alkali and harmful gas.

11.3 Transportation Precautions

The LCD modules should be no falling and violent shocking during transportation, and also should avoid excessive press, water, damp and sunshine.