



Product Specification

Model Name	KD101HWX34ED
Description	1280(RGB)x800 Dots 10.1" TFT LCD
Date	2020/08/18
Revision	2.0

Approved by/Date	Check by/Date	Prepared by/Date
ZHP 2020/08/18	HZX 2020/08/18	Yigui.Han 2020/08/18

Customer Approval	
Date	



Table of Contents

1 Record of Revision	3
2 General Specifications	4
3 Input/Output Terminals	5
4 Absolute Maximum Ratings	6
5 Electrical Characteristics	7
6 Optical Characteristics	11
7 Environmental / Reliability Tests	15
8 Mechanical Drawing	17
9 Packing	18
10 Precautions for Use of LCD modules	19

2 General Specifications

	Feature	Spec
Characteristics	Size	10.1 inch
	Resolution	1280(Horizontal)*800(Vertical)
	Interface	LVDS
	Connect type	Connector
	Color Depth	16.7M
	Technology type	a-Si
	Display Spec. Pixel pitch (mm)	0.1695(H)×0.1695(V)
	Pixel Configuration	R.G.B. Vertical Stripe
	Display Mode	Normally Black
	Driver IC	EK79202
	Viewing Direction	ALL
Mechanical	LCM (W x H x D) (mm)	229.46(W)*149.10(H)*4.5 (D)
	Active Area(mm)	216.96(H)x 135.60(V)
	With /Without TP	Without TP
	Weight (g)	TBD
	LED Numbers	45 LEDs

Note 1: Requirements on Environmental Protection: RoHS

Note 2: LCM weight tolerance: +/- 5%

3 Input/Output Terminals

No.	Symbol	Description	Note
1	NC	No connection	
2-3	VDD (3.3V)	Power Supply	
4	NC	No connection	
5	RESET(NC)	No connection	
6	STBYB(NC)	No connection	
7	GND	Ground	
8	RXIN0-	- LVDS differential data input	
9	RXIN0+	+ LVDS differential data input	
10	GND	Ground	
11	RXIN1-	- LVDS differential data input	
12	RXIN1+	+ LVDS differential data input	
13	GND	Ground	
14	RXIN2-	- LVDS differential data input	
15	RXIN2+	+ LVDS differential data input	
16	GND	Ground	
17	RXCLK-	- LVDS differential clock input	
18	RXCLK+	+ LVDS differential clock input	
19	GND	Ground	
20	RXIN3-	- LVDS differential data input	
21	RXIN3+	+ LVDS differential data input	
22	GND	Ground	
23	SDA(NC)	No connection	
24	SCL(NC)	No connection	
25	GND	Ground	
26	CS(NC)	No connection	
27	NC	No connection	
28	LVBIT(NC)	No connection	
29	NC	No connection	
30	GND	Ground	
31-32	LEDK	Power for LED backlight (Cathode)	
33-38	NC	No connection	
39-40	LEDA	Power for LED backlight (Anode)	



4 Absolute Maximum Ratings

Item	Symbol	MIN	Typ	MAX	Unit
Supply Voltage	VDD	-0.3	3.3	3.6	V
Input voltage "H" level	VIH	0.7VDD	-	VDD	V
Input voltage "L" level	VIL	0	-	0.3VDD	V
Operating Temperature	TOPR	-20	-	70	°C
Storage Temperature	TSTG	-30	-	80	°C

5 Electrical Characteristics

5.1 POWER ON/OFF SEQUENCE

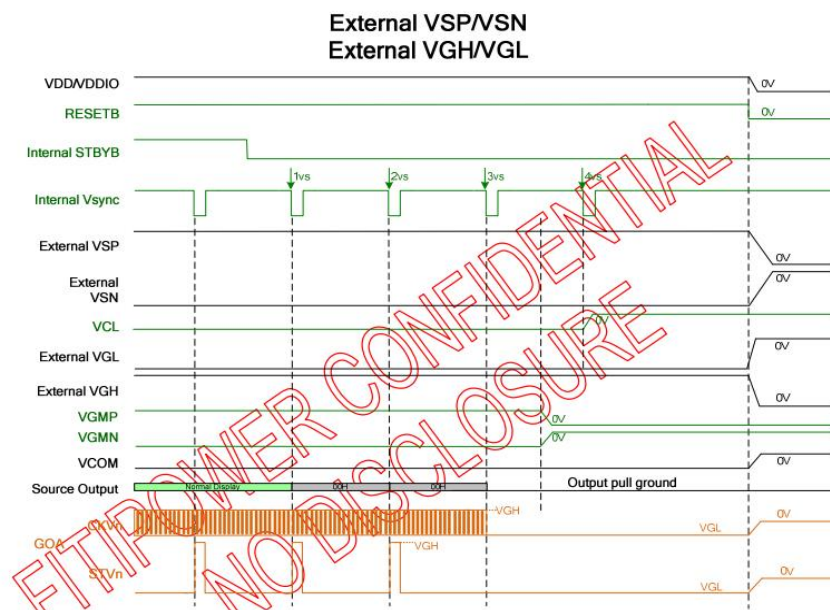
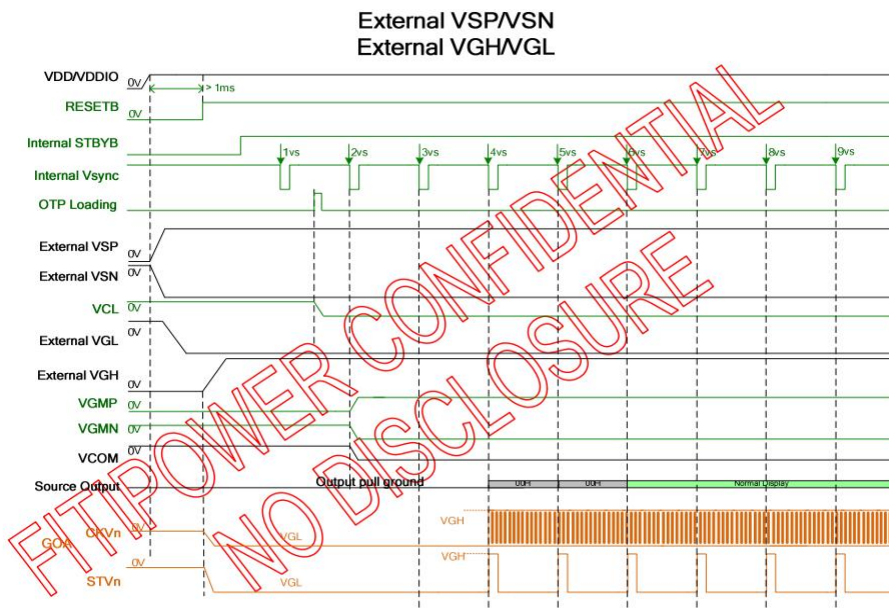

5.2 Driving Backlight

Item	Symbol	MIN	TYP	MAX	Unit	Remark
Forward Current	I_F	-	360	-	mA	
Forward Voltage	V_F	14V	16V	18V	V	
Backlight Power consumption	W_{BL}	-	5.76W	-	W	
LED Lifetime		-	50000	-	Hrs	

Note 1: Each LED: $I_F = 40 \text{ mA}$, $V_F = 3.2 \pm 0.3 \text{ V}$.

Note 2: Optical performance should be evaluated at $T_a = 25^\circ \text{C}$ only.

Note 3: If LED is driven by high current, high ambient temperature & humidity condition. The life Time of LED will be reduced. Operating life means brightness goes down to 50% initial brightness. Typical operating life time is estimated data.

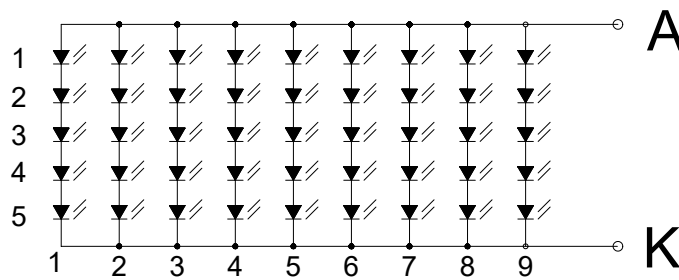

CIRCUIT DIAGRAM

5.3 RESET TIMING CHARACTERISTICS

When RESETB of the reset pin equals to Low, it will be in the condition of reset.
 When it is in the condition of reset, it will make the device recover the initial set.

However, in order to avoid the reset noise cause reset, there is a mechanism to judge about whether the reset is needed or not.

The closed interval of Low can be shown as the following.

(Test condition: VDDIO=2.3V~3.6V, VSS=0V, TA=-20 ~+85)

Parameter	Symbol	Conditions	Spec.			Unit
			Min.	Typ.	Max	
Reset low pulse width	Trst		20	-	-	μs

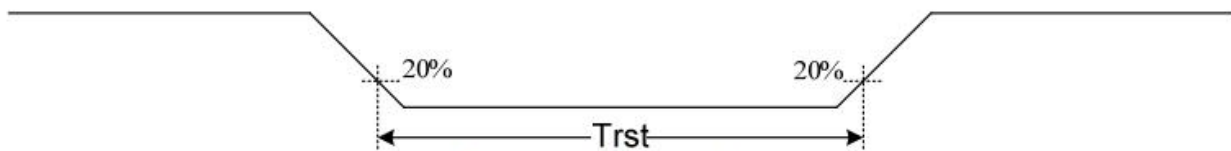
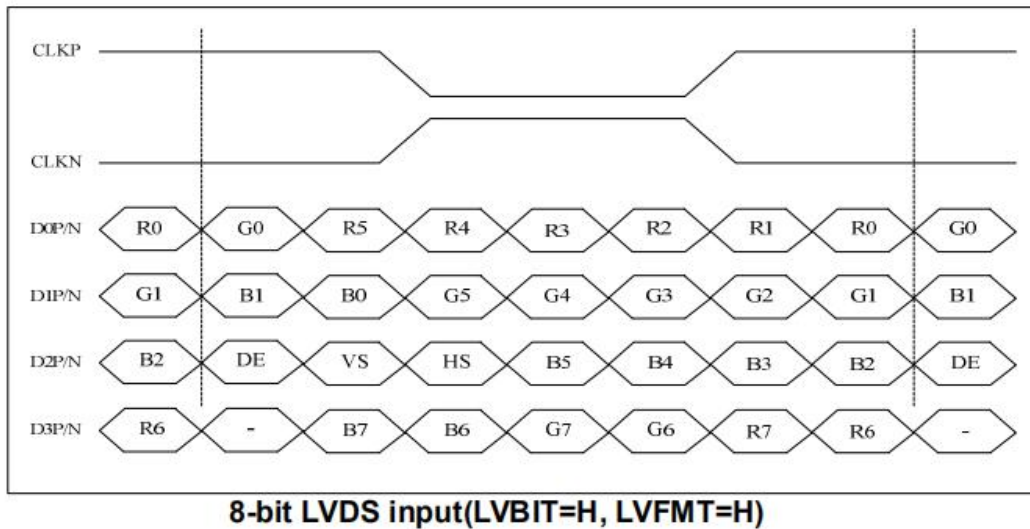

Figure 13.5: Reset timing

5.4 LVDS interface CHARACTERISTICS



For 1280RGBx800

Parameter	Symbol	Value			Unit
		Min.	Typ.	Max.	
DCLK frequency @Frame rate=60Hz (LVDS)	F _{DCLK}	66.3	72.4	78.9	MHz
HSYNC period time	T _H	1380	1440	1500	DCLK
Horizontal display area	T _{HD}	1280			DCLK
HSYNC pulse width	T _{HPW}	Min.	1		
		Typ.	-		
		Max.	40		
HSYNC back porch(with pulse width)	T _{HBP}	88	88	88	DCLK
HSYNC front porch	T _{HFP}	12	72	132	DCLK
VSYNC period time	T _V	824	838	872	H
Vertical display area	T _{VD}	800			H
VSYNC pulse width	T _{VPW}	Min.	1		H
		Typ.	-		
		Max.	20		
VSYNC back porch(with pulse width)	T _{VBP}	23	23	23	H
VSYNC front porch	T _{VFP}	1	15	49	H

6 Optical Characteristics

Items	Symbol	Condition	Min.	Typ.	Max.	Unit	Remark	
Viewing angles	θ_T	Center CR \geq 10		80	-	Degree.	Note2	
	θ_B			80	-			
	θ_L			80	-			
	θ_R			80	-			
Contrast Ratio	CR	$\Theta = 0$	800	1000	-	-	Note1, Note3	
Response Time	T_{ON}	25°C	-	25	35	ms	Note1, Note4	
	T_{OFF}							
Chromaticity	Red	Backlight is on	X_W	0.568	0.618	0.668	-	Note1, Note5
			Y_W	0.278	0.328	0.378	-	Note5
	Green		X_W	0.285	0.335	0.385	-	Note1, Note5
			Y_W	0.492	0.542	0.592	-	Note5
	Blue		X_W	0.086	0.136	0.186	-	Note1, Note5
			Y_W	0.095	0.145	0.195	-	Note5
	White		X_W	0.272	0.322	0.372	-	Note1, Note5
			Y_W	0.294	0.344	0.394	-	Note5
Luminance Uniformity	LU		70	75	-	%	Note1, Note6	
Luminance	L		800	1000		cd/m ²	Note1, Note7	

Test Conditions:

1. IF= 20mA(one channel),the ambient temperature is 25°C.
2. The test systems refer to Note 1 and Note 2.

Note 1:Definition of optical measurement system.

The optical characteristics should be measured in dark room. After 5 minutes operation, the optical properties are measured at the center point of the LCD screen. All input terminals LCD panel must be ground when measuring the center area of the panel.

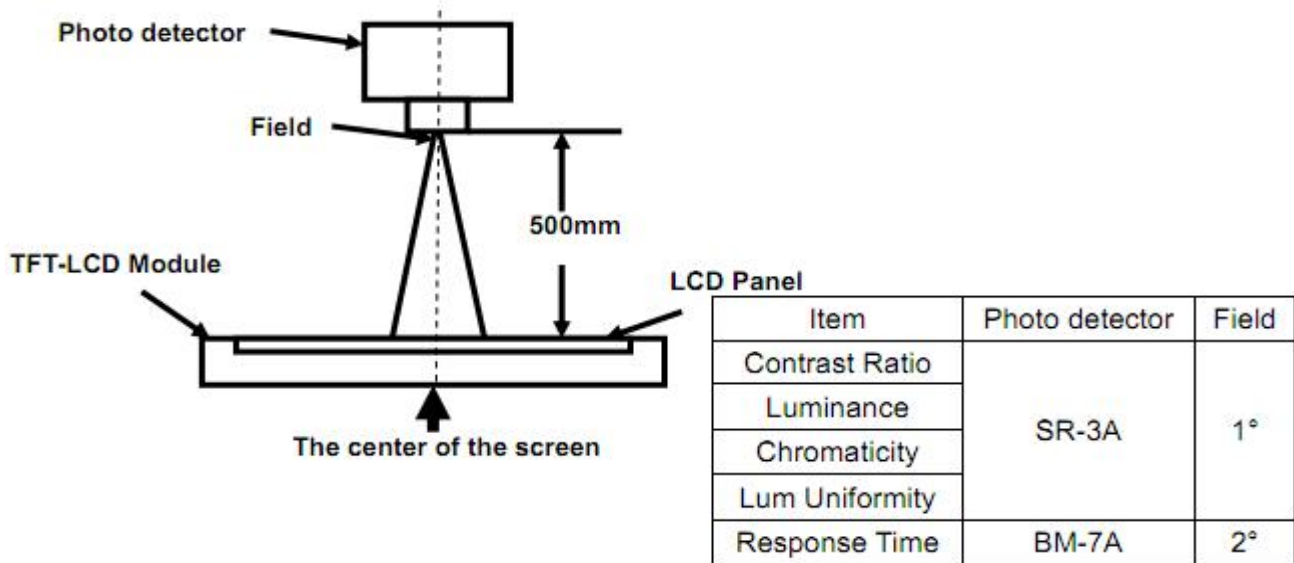

Note 2: Definition of viewing angle range and measurement system.

viewing angle is measured at the center point of the LCD by CONOSCOPE(ergo-80).

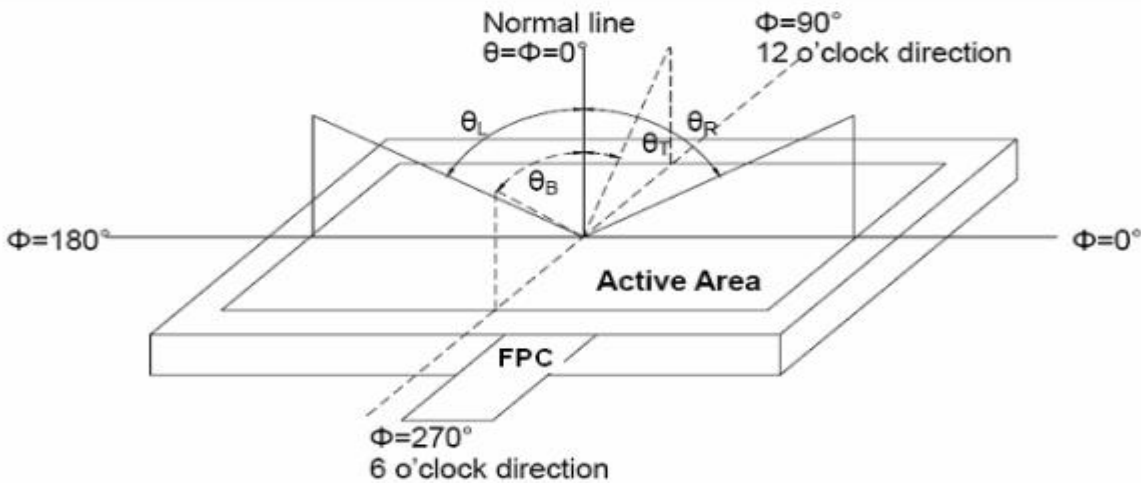

Fig. 1 Definition of viewing angle

Note 3: Definition of contrast ratio

$$\text{Contrast ratio (CR)} = \frac{\text{Luminance measured when LCD is on the "White" state}}{\text{Luminance measured when LCD is on the "Black" state}}$$

“White state “:The state is that the LCD should driven by Vwhite.

“Black state”: The state is that the LCD should driven by Vblack.

Vwhite: To be determined Vblack: To be determined.

Note 4: Definition of Response time

The response time is defined as the LCD optical switching time interval between “White” state and “Black” state. Rise time (TON) is the time between photo detector output intensity changed from 90% to 10%. And fall time (TOFF) is the time between photo detector output intensity changed from 10% to 90%.

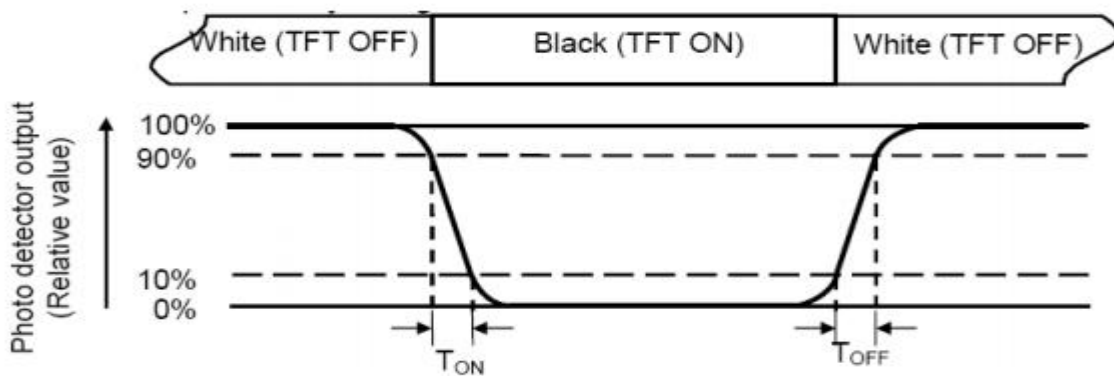

Note 5: Definition of color chromaticity (CIE1931)

Color coordinates measured at center point of LCD.

Note 6: Definition of Luminance Uniformity

Active area is divided into 9 measuring areas (Refer Fig. 2). Every measuring point is placed at the center of each measuring area.

$$\text{Luminance Uniformity}(U) = L_{\min} / L_{\max} \times 100\%$$

L-----Active area length W----- Active area width

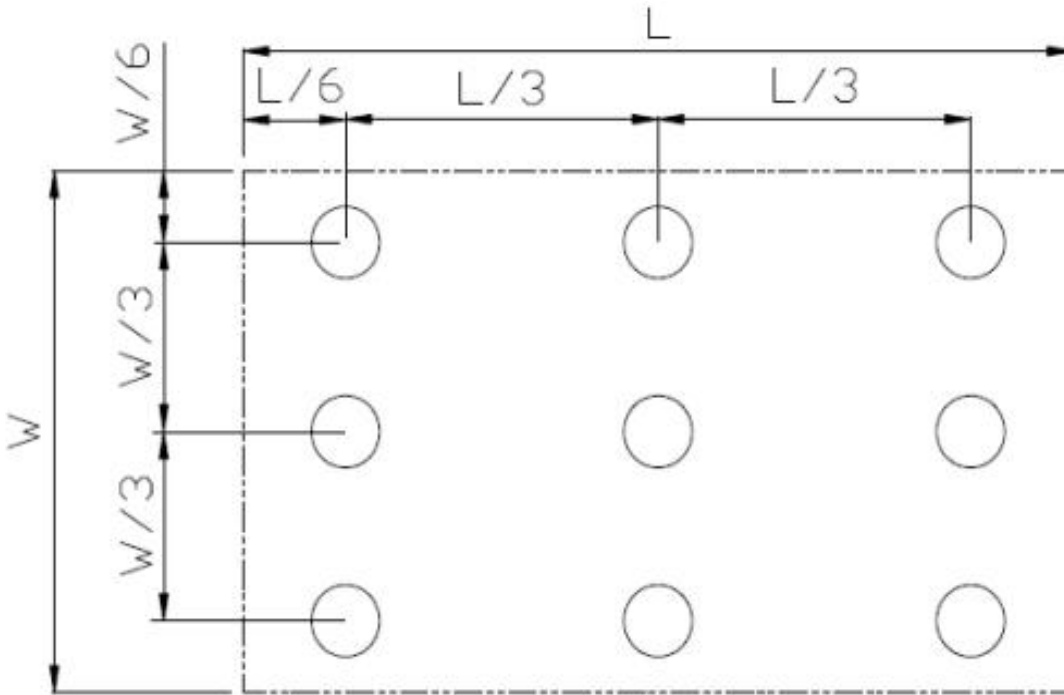

Fig. 2 Definition of uniformity

L_{max} : The measured maximum luminance of all measurement position.

L_{min} : The measured minimum luminance of all measurement position.

Note 7: Definition of Luminance :

Measure the luminance of white state at center point.

7 Environmental / Reliability Tests

No	Test Item	Condition	Remarks
1	High Temperature Operation	Ts= +70°C, 96hrs	IEC60068-2-1:2007 GB2423. 2-2008
2	Low Temperature Operation	Ta= -20°C, 96hrs	IEC60068-2-1:2007 GB2423.1-2008
3	High Temperature Storage	Ta= +80°C, 96hrs	IEC60068-2-1:2007 GB2423. 2-2008
4	Low Temperature Storage	Ta= -30°C, 96hrs	IEC60068-2-1:2007 GB2423.1-2008
5	High Temperature & Humidity Operation	Ta= +60°C, 90% RH max, 96 hours	IEC60068-2-78:2001 GB/T2423.3-2006
6	Thermal Shock (Non-operation)	-30°C 30 min ~ +80°C 30 min Change time: 5min, 20 Cycle	Start with cold temperature, end with high temperature IEC60068-2-14:1984, GB2423.22-2002
7	ESD	C=150pF, R=330 Ω, 5 points/panel , Air:±8KV, 5 times Contact: ±4KV, 5 times (Environment: 15°C ~ 35°C, 30% ~ 60%, 86Kpa ~ 106Kpa)	IEC61000-4-2:2001 GB/T17626.2-2006
8	Vibration (Non-operation)	Frequency range: 10~55Hz, Stroke: 1.5mm , Sweep: 10Hz~55Hz~10Hz 2 hours for each direction of X .Y. Z. (6 hours for total)	IEC60068-2-6:1982 GB/T2423.10-1995
9	Mechanical Shock (Non-operation)	Half Sine Wave 60G ,6ms,±X,±Y,±Z 3times for each direction	IEC60068-2-27:1987 GB/T2423.5—1995
10	Package Drop Test	Height: 60 cm, 1 corner, 3 edges, 6 surfaces	IEC60068-2-32:1990 GB/T2423.8-1995



Notes:

1. The test result shall be evaluated after the sample has been left at room temperature and humidity for 2 hours without load. No condensation shall be accepted. The sample will not be accepted if appear these defects:

- 1).Air bubble in the LCD;
- 2).Seal leak
- 3).Non-display
- 4).missing segments
- 5).Glass crack
- 6).CR reduction >40%
- 7).IDD increase >100%
- 8).Brightness reduction >50%
- 9).Color coordinate tolerance >0.05

2.≤7.0 inch: The size of sample is 5pcs;

>7.0 inch: The size of sample is 2pcs;

3. One test sample must complete each test item;

4.In case of malfunction defect caused by ESD damage, if it would be recovered to normal state after resetting, it would be judge as a good part.

5.In the test of High Temperature Operation and High Temperature & Humidity Operation ,the operation temperature is the surface temperature of module.

8 Mechanical Drawing

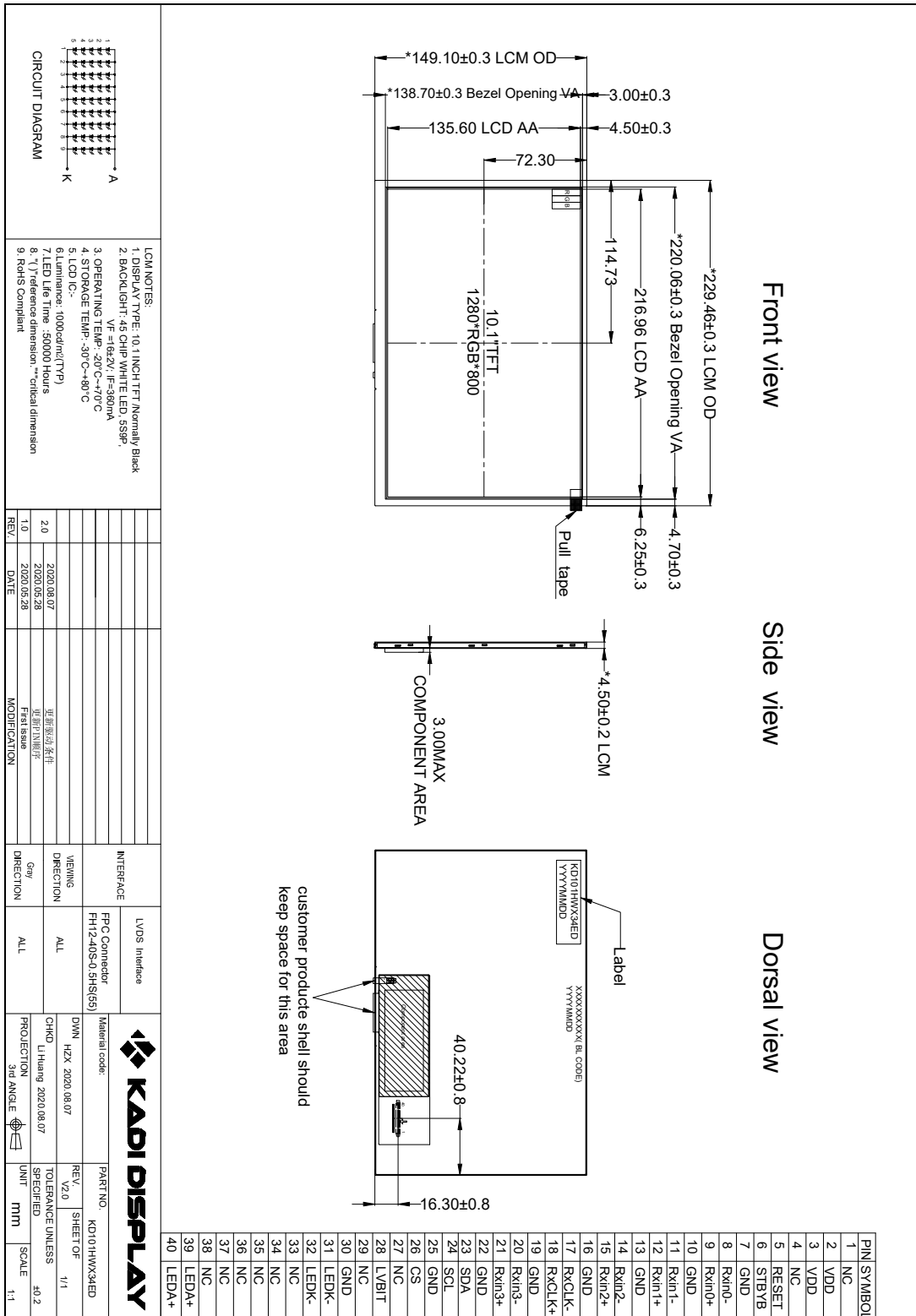

9 Packing

Packing Method

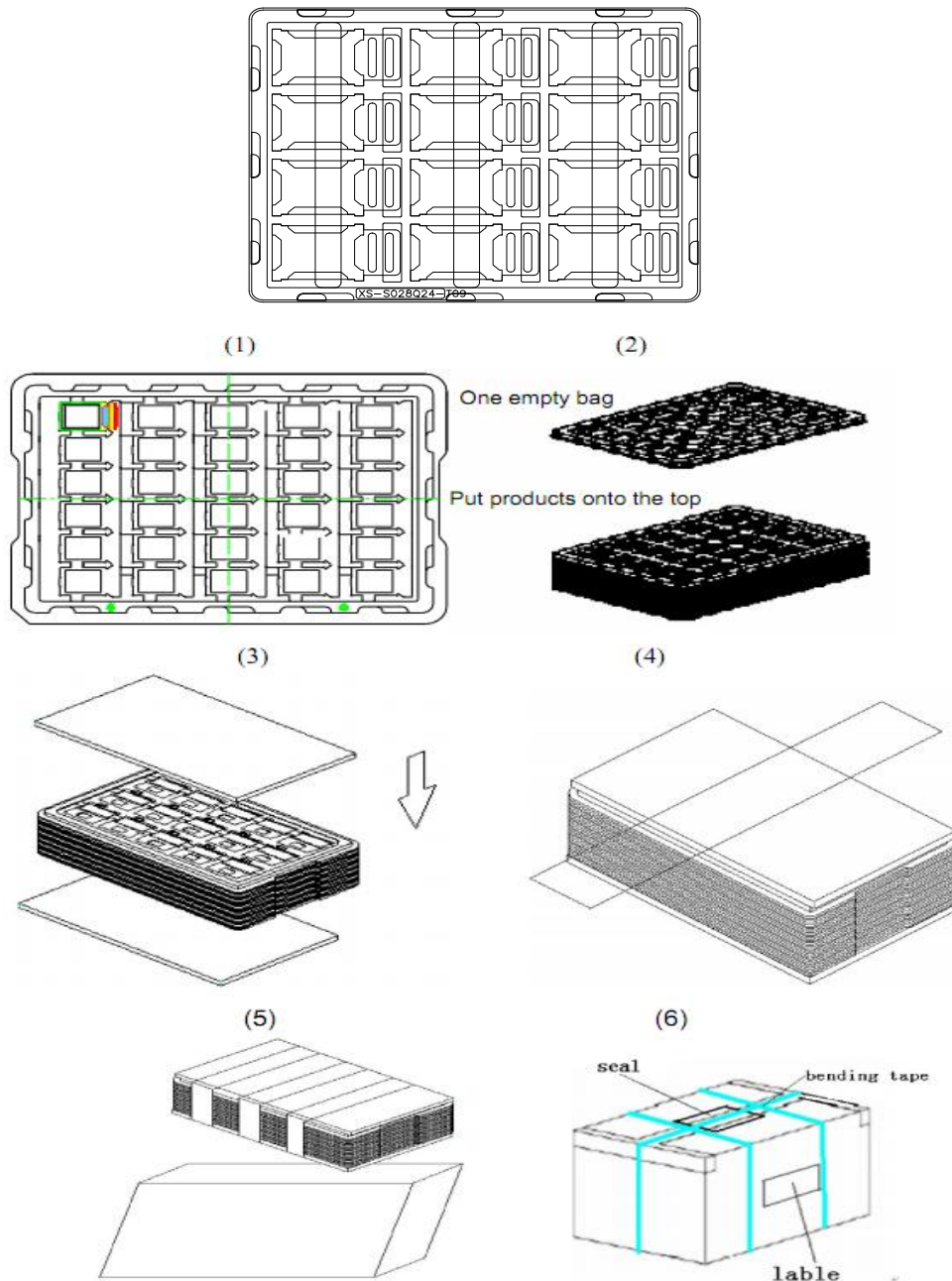

1. Put module into tray cavity:
2. Tray stacking
3. Put 1 cardboard under the tray stack and 1 cardboard above:
4. Fix the cardboard to the tray stack with adhesive tape:
5. Put the tray stack into carton.
6. Carton sealing with adhesive tape.

10 Precautions for Use of LCD modules

10.1 Handling Precautions

10.1.1. The display panel is made of glass. Do not subject it to a mechanical shock by dropping it from a high place, etc.

10.1.2. If the display panel is damaged and the liquid crystal substance inside it leaks out, be sure not to get any in your mouth, if the substance comes into contact with your skin or clothes, promptly wash it off using soap and water.

10.1.3. Do not apply excessive force to the display surface or the adjoining areas since this may cause the color tone to vary.

10.1.4. The polarizer covering the display surface of the LCD module is soft and easily scratched. Handle this polarizer carefully.

10.1.5. If the display surface is contaminated, breathe on the surface and gently wipe it with a soft dry cloth. If still not completely clear, moisten cloth with one of the following solvents:

- Isopropyl alcohol
- Ethyl alcohol

Solvents other than those mentioned above may damage the polarizer. Especially, do not use the following:

- Water
- Ketene

10.1.6. Do not attempt to disassemble the LCD Module.

10.1.7. If the logic circuit power is off, do not apply the input signals.

10.1.8. To prevent destruction of the elements by static electricity, be careful to maintain an optimum work environment.

10.1.8.1. Be sure to ground the body when handling the LCD Modules.

10.1.8.2. Tools required for assembly, such as soldering irons, must be properly ground.

10.1.8.3. To reduce the amount of static electricity generated, do not conduct assembly and other work under dry conditions.

10.1.8.4. The LCD Module is coated with a film to protect the display surface. Be care when peeling off this protective film since static electricity may be generated.

10.2 Storage Precautions

10.2.1. When storing the LCD modules, avoid exposure to direct sunlight or to the light of fluorescent lamps.

10.2.2. The LCD modules should be stored under the storage temperature range. If the LCD modules will be stored for a long time, the recommend condition is:

Temperature : 0°C ~ 40°C Relatively humidity: ≤80%

10.2.3. The LCD modules should be stored in the room without acid, alkali and harmful gas.

10.3 Transportation Precautions

The LCD modules should be no falling and violent shocking during transportation, and also should avoid excessive press, water, damp and sunshine.