



Product Specification

Model Name	KD070HWX73HP
Description	800(RGB)x1280 Dots 7" TFT LCD
Date	2021/03/12
Revision	1.0

Approved by/Date	Check by/Date	Prepared by/Date
ZHP 2021/03/12	HZX 2021/03/12	ZWF 2021/03/12

Customer Approval	
Date	



Table of Contents

1. Record of Revision	3
2 General Specifications	4
3 Input/Output Terminals	5
4 Absolute Maximum Ratings	6
5 Electrical Characteristics	7
6 Optical Characteristics	15
7 Environmental / Reliability Tests	17
8 Mechanical Drawing	19
9 Packing	20
10 Precautions for Use of LCD modules.....	21

2 General Specifications

	Feature	Spec
Characteristics	Size	7 inch
	Resolution	800(Horizontal)*1280(Vertical)
	Interface	MIPI
	Connect type	Connector
	Color Depth	16.7M
	Technology type	a-Si
	Display Spec. Pixel pitch (mm)	0.117(H)×0.117(V)
	Pixel Configuration	R.G.B. Vertical Stripe
	Display Mode	Normally Black
	Driver IC	JD9365D
	Viewing Direction	full view
Mechanical	LCM (W x H x D) (mm)	99.71(W)*160.91(H)*2.46 (D)
	Active Area(mm)	94.2(H)x 150.72(V)
	With /Without TSP	Without TSP
	Weight (g)	TBD
	LED Numbers	24 LEDs

Note 1: Viewing direction is follow the data which measured by optics equipment.

Note 2: Requirements on Environmental Protection: RoHS

Note 3: LCM weight tolerance: +/- 5%

3 Input/Output Terminals

LCD PIN-MAP

No	Symbol	Description
1~3	LED+	LED anode
4	NC	No connect
5~8	LED-	LED-
9	GND	GROUND
10	GND	GROUND
11	MIPI_D2P	MIPI Positive data signal(+)
12	MIPI_D2N	MIPI Negative data signal(-)
13	GND	GROUND
14	MIPI_D1P	MIPI Positive data signal(+)
15	MIPI_D1N	MIPI Negative data signal(-)
16	GND	GROUND
17	MIPI_CKP	MIPI Positive clock signal(+)
18	MIPI_CKN	MIPI Negative clock signal(-)
19	GND	GROUND
20	MIPI_D0P	MIPI Positive data signal(+)
21	MIPI_D0N	MIPI Negative data signal(-)
22	GND	GROUND
23	MIPI_3P	MIPI Positive data signal(+)
24	MIPI_3N	MIPI Negative data signal(-)
25	GND	GROUND
26	ID(NC)	No connect
27	RST(3.3V)	Device reset signal
28	NC	No connect
29	VDD(3.3V)	Power supply for logic operation
30	VDD(3.3V)	Power supply for logic operation
31	VDD(3.3V)	Power supply for logic operation



4 Absolute Maximum Ratings

Item	Symbol	MIN	Typ	MAX	Unit	Remark
Supply Voltage	VDD	-0.3	-	5.0	V	-
TFT Gate on voltage	VGH	-0.3	-	18	V	
TFT Gate off voltage	VGL	-18	-	0.3	V	
Analog power supply voltage	AVDD	3.6		5.5	V	
	AVEE	-5.5		-3.6	V	
Operating Temperature	TOPR	-20	-	70	°C	-
Storage Temperature	TSTG	-30	-	80	°C	

5 Electrical Characteristics

5.1 Driving TFT LCD Panel

Item	Symbol	MIN	Typ	MAX	Unit	Remark
Supply Voltage	VDD	3.0	3.3	3.6	V	-
Current of power supply	I _{VDD}	-	97	110	mA	
Input voltage “H”level	V _{IH}	0.7VDD	-	VDD	V	-
Input voltage “L”level	V _{IL}	0	-	0.3VDD	V	

5.2 Driving Backlight

Item	Symbol	MIN	TYP	MAX	Unit	Remark
Forward Current	I _F	-	80	-	mA	
Forward Voltage	V _F	16.0	18	20.0	V	
Backlight Power consumption	W _{BL}	-	1.44	-	W	
LED Lifetime		-	30000	-	Hrs	

Note 1: Each LED : I_F =20 mA, V_F =2.8~3.4V.

Note 2: Optical performance should be evaluated at Ta=25°C only.

Note 3: If LED is driven by high current, high ambient temperature & humidity condition. The life time of LED will be reduced. Operating life means brightness goes down to 50% initial brightness. Typical operating life time is estimated data.

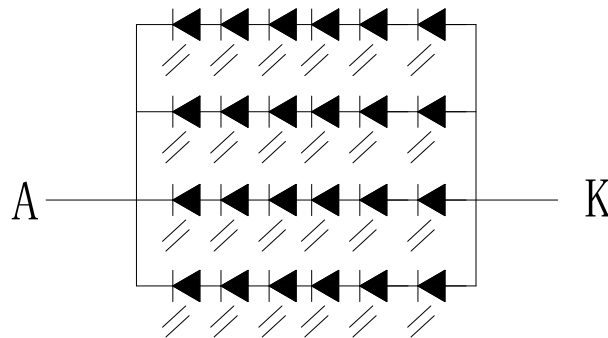
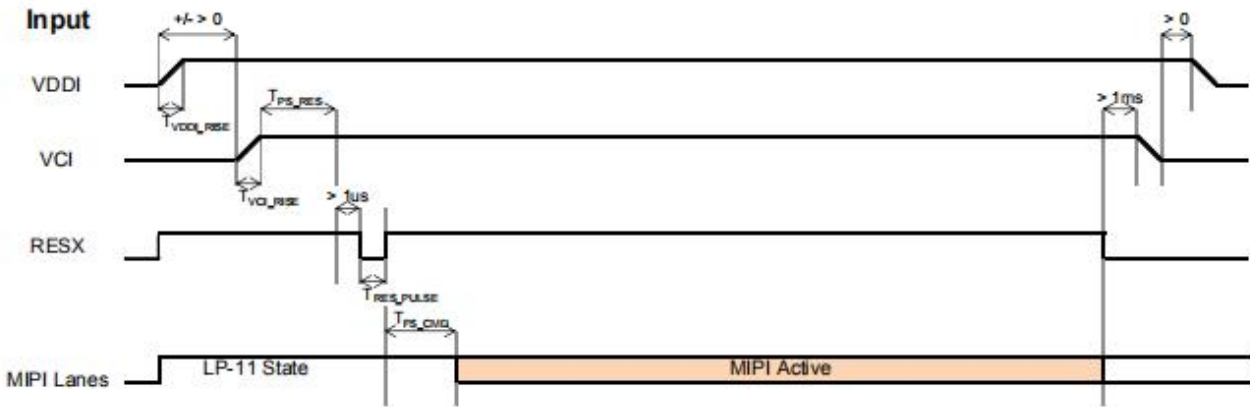

Figure : LED connection of backlight

5.2 POWER ON/OFF SEQUENCE

Case A:



Case B:

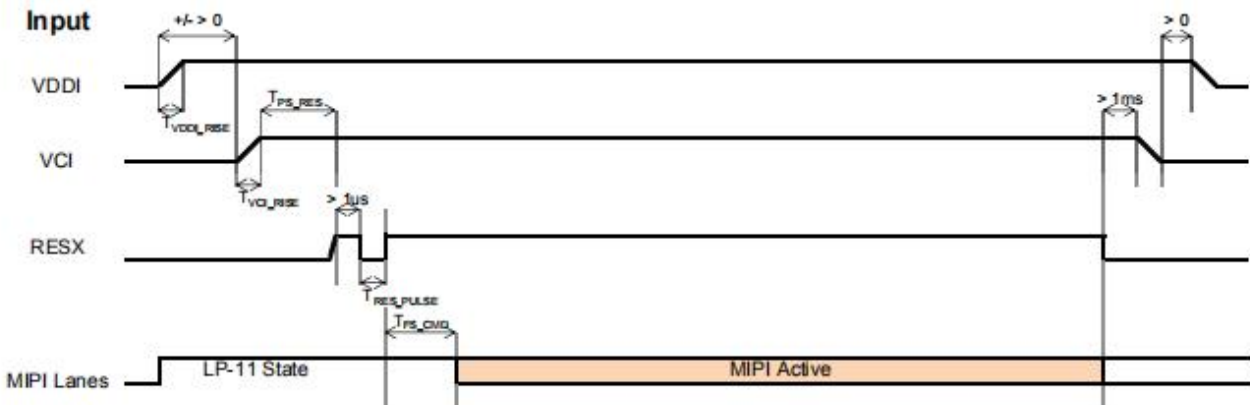

Symbol	Characteristics	Min.	Typ.	Max.	Units
T_{VDDI_RISE}	VDDI Rise time	10	-	-	us
T_{VCI_RISE}	Case A: VCI Rise time	130	-	-	us
	Case B: VCI Rise time	40	-	-	us
T_{PS_RES}	VDDI/VCI on to Reset high	5	-	-	ms
T_{RES_PULSE}	Reset low pulse time	10	-	-	us
T_{FS_CMD}	Reset to first command	10	-	-	ms

Figure 93: Power on/off sequence with Power Mode 3

5.5 RESET TIMING CHARACTERISTICS

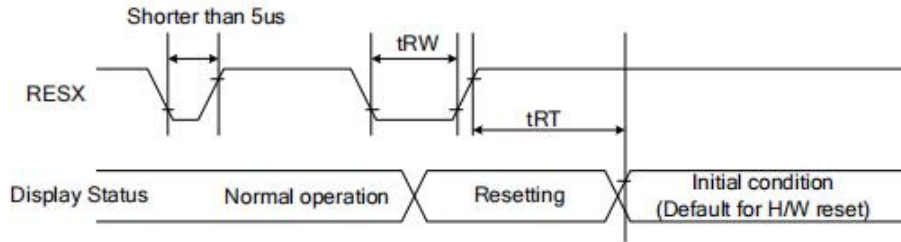

Figure 113: Reset Timing

Table 47: Reset Timing

Signal	Symbol	Parameter	Min	Max	Unit
RESX	tRW	Reset pulse duration	10	5 (note 1,5)	uS
	tRT	Reset cancel		120 (note 1,6,7)	mS

Notes:

1. The reset cancel also includes required time for loading ID bytes, VCOM setting and other settings from EEPROM to registers. This loading is done every time when there is H/W reset cancel time (tRT) within 5 ms after a rising edge of RESX.
2. Spike due to an electrostatic discharge on RESX line does not cause irregular system reset according to the Table 48.

Table 48: Reset Descript

RESX Pulse	Action
Shorter than 5us	Reset Rejected
Longer than 10us	Reset
Between 5us and 10us	Reset starts

3. During the Resetting period, the display will be blanked (The display enters the blanking sequence, which maximum time is 120 ms, when Reset Starts in the Sleep Out mode. The display remains the blank state in the Sleep In mode.) and then return to Default condition for Hardware Reset.
4. Spike Rejection can also be applied during a valid reset pulse, as shown below:

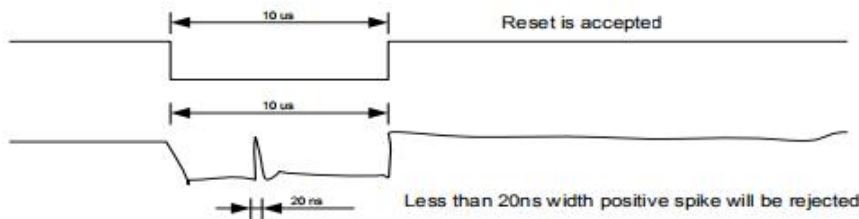

Figure 114: Positive Noise Pulse during Reset Low

5. When Reset applied during Sleep In Mode.
6. When Reset applied during Sleep Out Mode.
7. It is necessary to wait 5msec after releasing RESX before sending commands. Also Sleep Out command cannot be sent for 120msec.

5.6 MIPI-DSI CHARACTERISTICS

5.6.1 High Speed Mode - Data Clock Channel Timing

CLKP/N lanes can be driven to the High Speed Clock Mode (HSCM) when CLK lanes start to function between HS-0 and HS-1 State Codes. The only entering possibility is from the Low Power Mode (LPM, LP-11 State Code) => LP-01 => LP-00 => HS-0 => HS-0/1 (HSCM). This sequence is illustrated below.

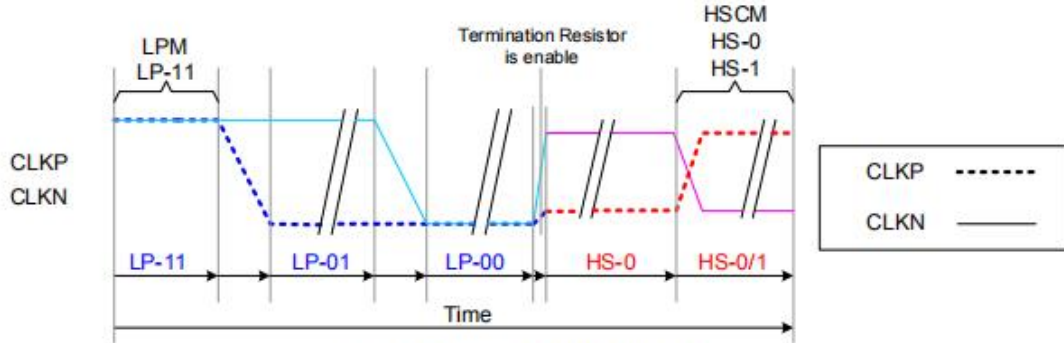

Figure 9: From LPM to HSCM

The mode change is also illustrated below.

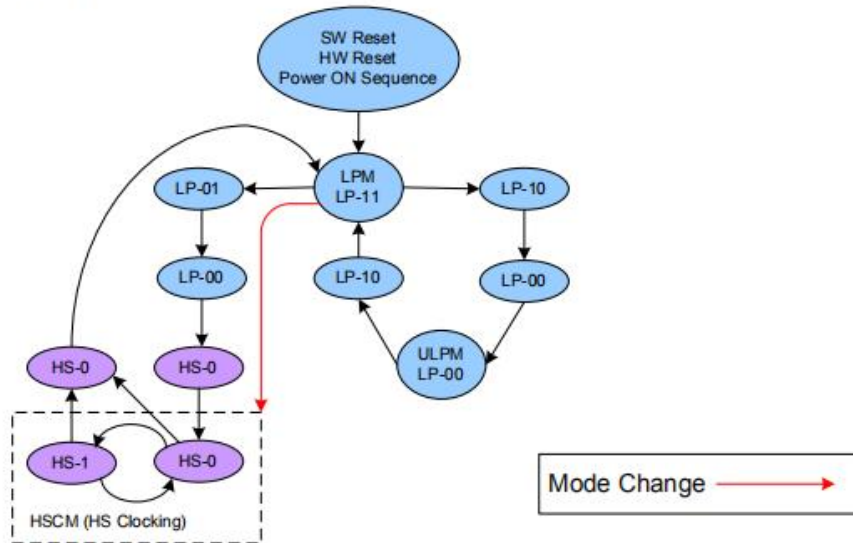

Figure 10: Mode Change from LPM to HSCM

The high speed clock (CLKP/N) starts before high speed data is sent via data lanes. The high speed clock continues clocking after the high speed data sending is stopped.

The burst of the high speed clock consists of:

- Even number of transitions
- Start state is HS-0
- End state is HS-0

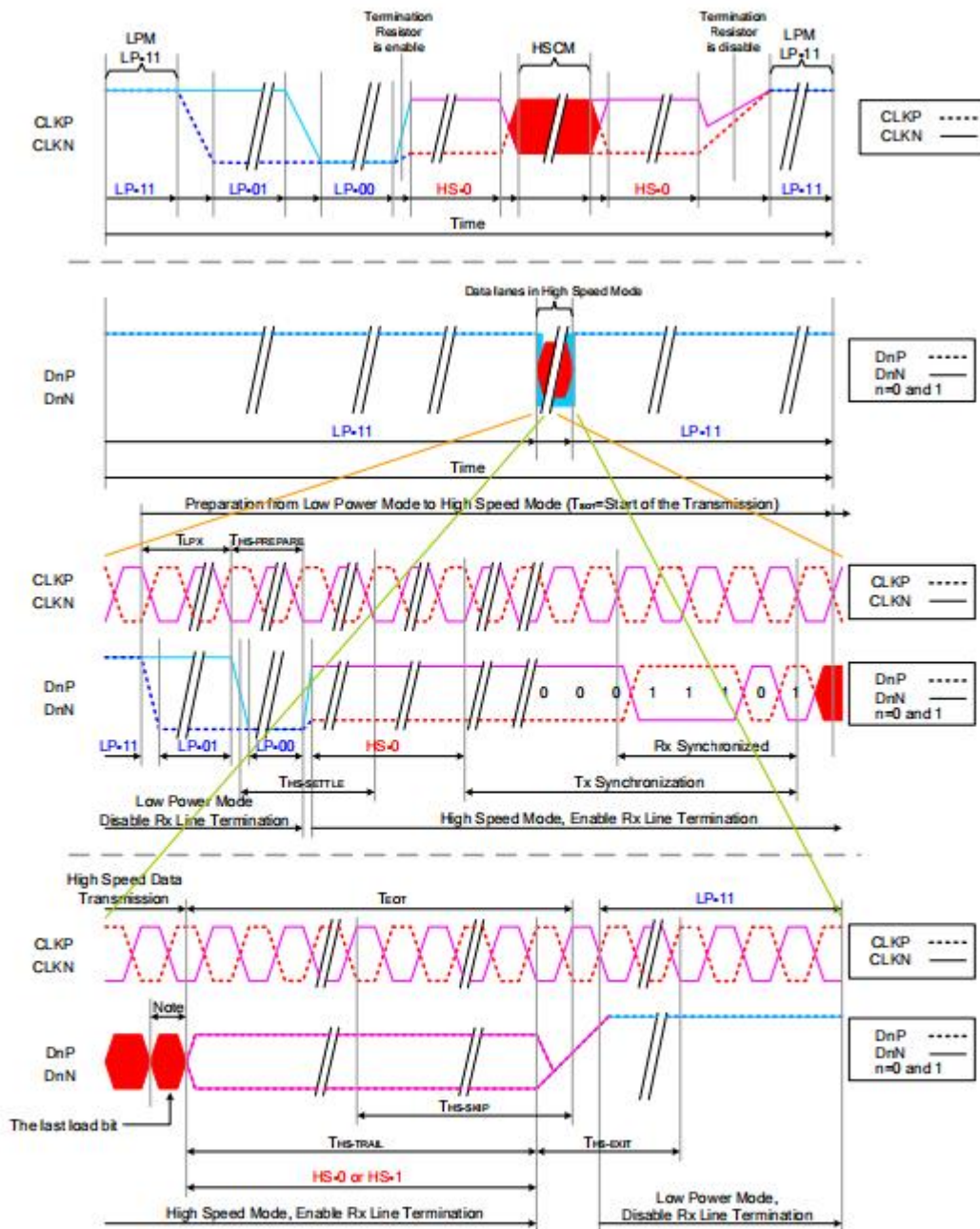
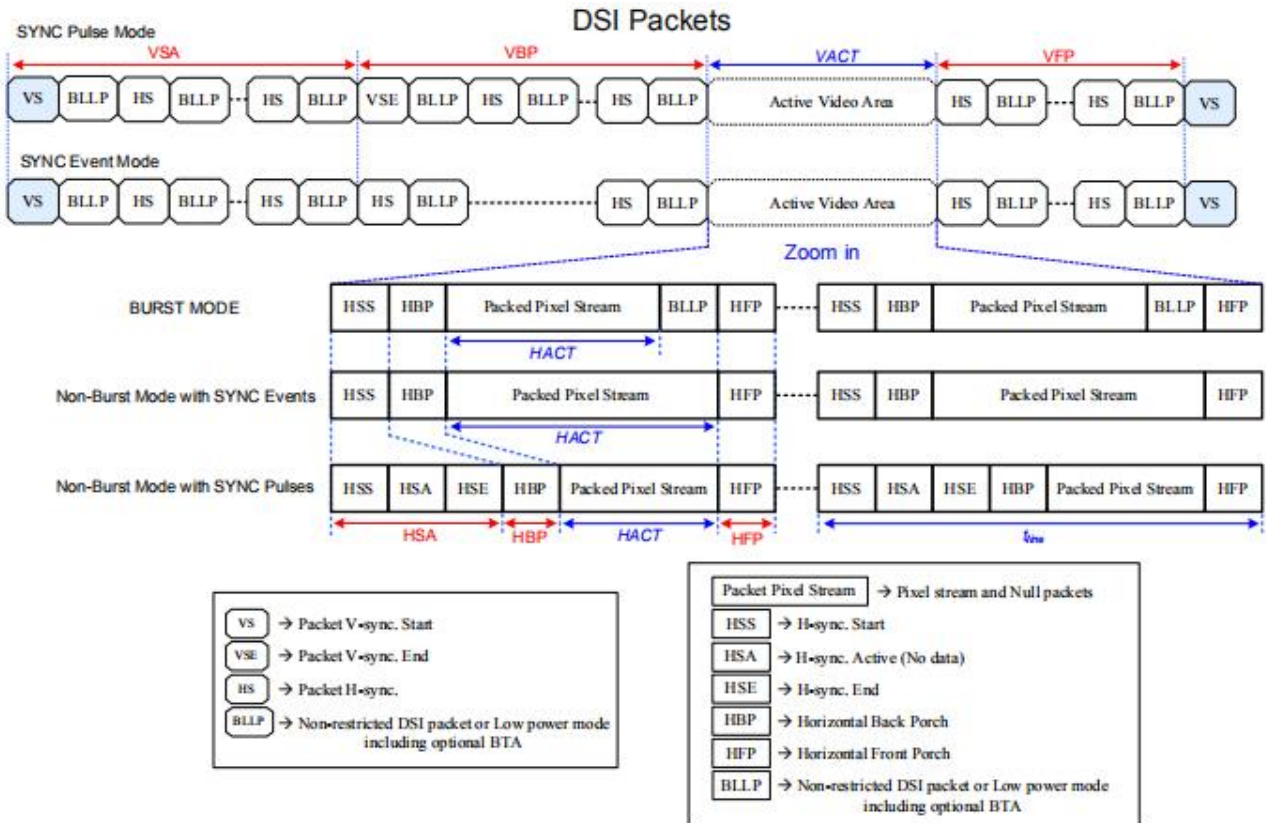

Figure 11: High Speed Clock Burst

Notes:

1. If the last load bit is HS-0, the transmitter changes from HS-0 to HS-1.
2. If the last load bit is HS-1, the transmitter changes from HS-1 to HS-0.

5.6.2 Timing for DSI video mode



Parameters	Symbols	Min.	Typ.	Max.	Units
Vertical sync. active	VSA	2 (Note 6)	-	-	Line
Vertical Back Porch	VBP	14 (Note 6)	-	-	Line
Vertical Front Porch	VFP	8 (Note 6)	-	-	Line
Active lines per frame	VACT	-	1280	-	Line
Horizontal sync. active	HSA	2	-	-	Pixel
Horizontal Porch period	HSA + HBP + HFP	1.6	-	-	us
Active pixels per line	HACT	-	720	-	Pixel
Bit rate	BR _{bps}	385		Note 5	Mbps/lane

1 UI=1/Bit rate

HSA(pixel)= (tHSA*lane number) / (UI* pixel format)

HBP(pixel)= (tHBP*lane number) / (UI* pixel format)

HFP(pixel)= (tHFP*lane number) / (UI* pixel format)

$$\text{Frame Rate} = \frac{\text{BR}_{\text{bps}} \times \text{Lane}_{\text{num}}}{(\text{VACT} + \text{VSA} + \text{VBP} + \text{VFP}) \times (\text{HACT} + \text{HSA} + \text{HBP} + \text{HFP}) \times \text{Pixel Format}}$$

Example : BR_{bps} = 457Mbps/lane, 1UI=2.1883ns, Frame rate=60Hz, VACT=1280, VSA=2, VBP=30, VFP=20, HACT=720, HSA=33, HBP=100, HFP=100, Lane_{num}=4(lane), Pixel Format=24(bit).

6 Optical Characteristics

Items	Symbol	Condition	Min.	Typ.	Max.	Unit	Remark	
Viewing angles	θ_T	Center CR \geq 10		85	-	Degree.	Note2	
	θ_B			85	-			
	θ_L			85	-			
	θ_R			85	-			
Contrast Ratio	CR	$\Theta = 0$	600	800	-	-	Note1, Note3	
Response Time	T_{ON}	25°C	-	30	40	ms	Note1, Note4	
	T_{OFF}							
Chromaticity	White	Backlight is on	X_W	0.263	0.313	0.363	-	Note1, Note5
			Y_W	0.273	0.320	0.373	-	
	Red		X_R	0.603	0.653	0.703	-	
			Y_R	0.280	0.330	0.380	-	
	Green		X_G	0.274	0.324	0.374	-	
			Y_G	0.522	0.572	0.622	-	
	Blue		X_B	0.084	0.134	0.184	-	
			Y_B	0.068	0.118	0.168	-	
Luminance Uniformity	LU		70	75	-	%	Note1, Note6	
Luminance	L		400	450		cd/m ²	Note1, Note7	

Test Conditions:

1. IF= 20mA(one channel),the ambient temperature is 25°C.
2. The test systems refer to Note 1 and Note 2.

Note 1:Definition of optical measurement system.

The optical characteristics should be measured in dark room. After 5 minutes operation, the optical properties are measured at the center point of the LCD screen. All input terminals LCD panel must be ground when measuring the center area of the panel.

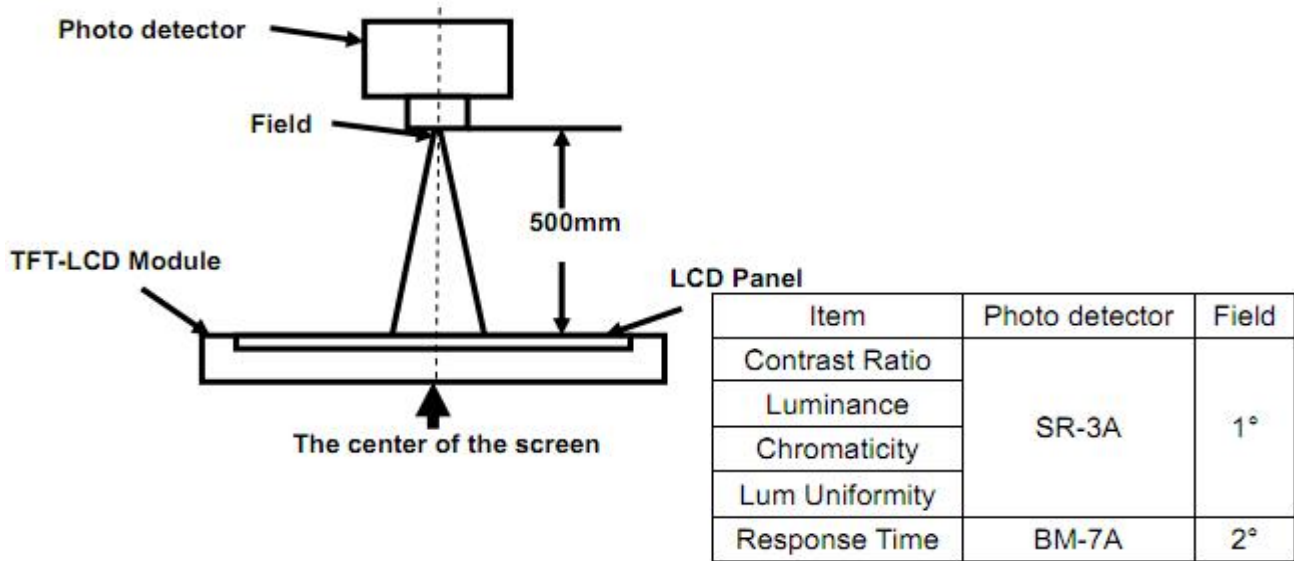

Note 2: Definition of viewing angle range and measurement system.
viewing angle is measured at the center point of the LCD by CONOSCOPE(ergo-80).

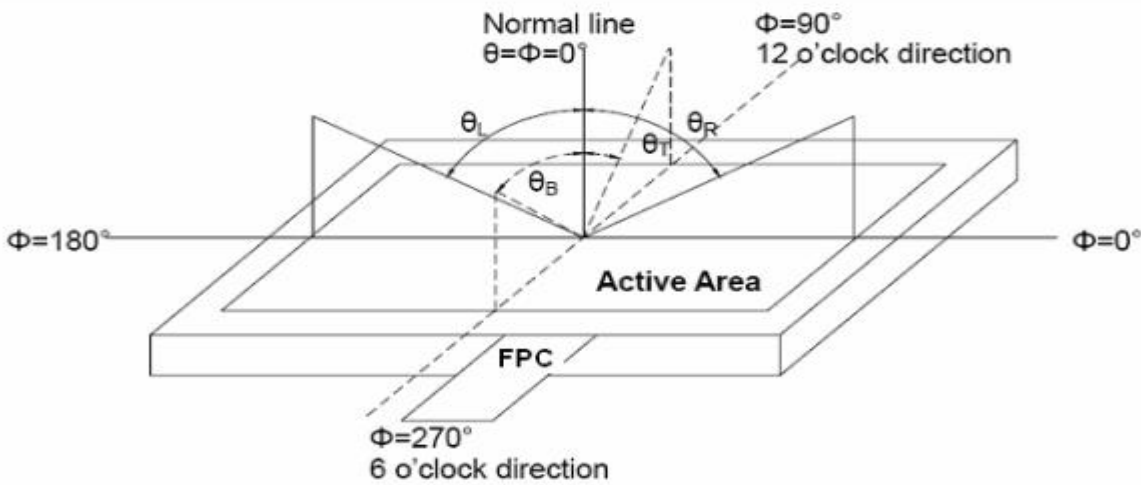

Fig. 1 Definition of viewing angle

Note 3: Definition of contrast ratio

$$\text{Contrast ratio (CR)} = \frac{\text{Luminance measured when LCD is on the "White" state}}{\text{Luminance measured when LCD is on the "Black" state}}$$

“White state “:The state is that the LCD should driven by Vwhite.

“Black state”: The state is that the LCD should driven by Vblack.

Vwhite: To be determined Vblack: To be determined.

Note 4: Definition of Response time

The response time is defined as the LCD optical switching time interval between “White” state and “Black” state. Rise time (TON) is the time between photo detector output intensity changed from 90% to 10%. And fall time (TOFF) is the time between photo detector output intensity changed from 10% to 90%.

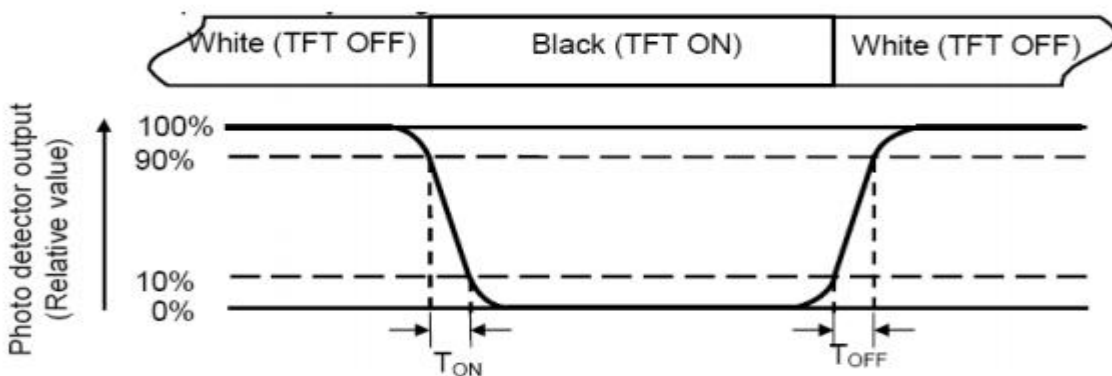

Note 5: Definition of color chromaticity (CIE1931)

Color coordinates measured at center point of LCD.

Note 6: Definition of Luminance Uniformity

Active area is divided into 9 measuring areas (Refer Fig. 2). Every measuring point is placed at the center of each measuring area.

$$\text{Luminance Uniformity}(U) = L_{\min} / L_{\max} \times 100\%$$

L-----Active area length W----- Active area width

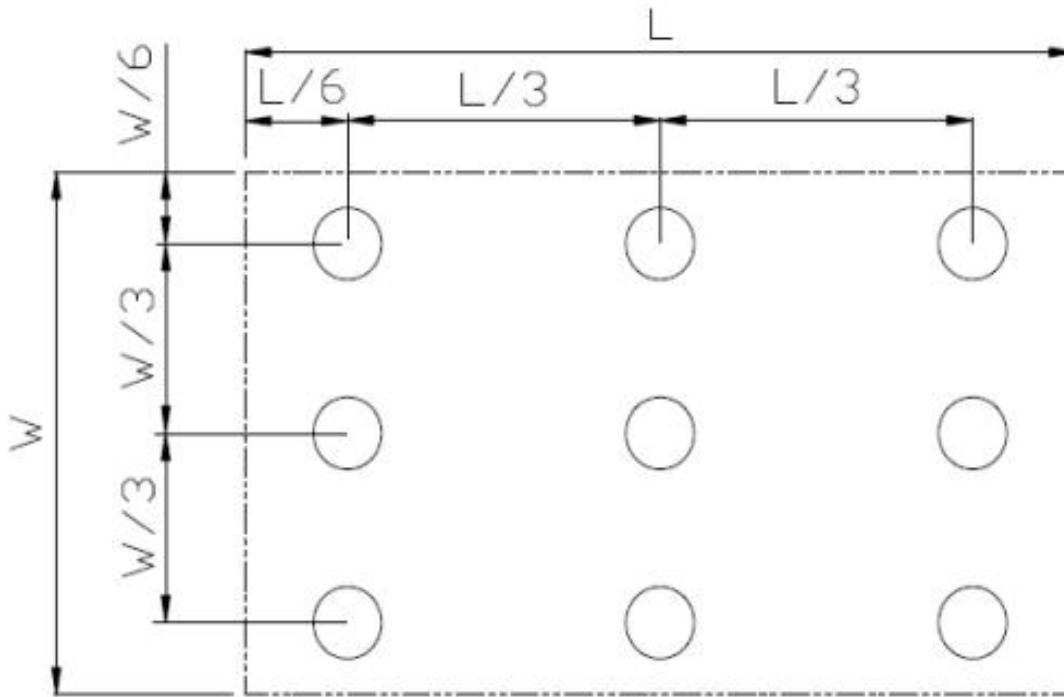

Fig. 2 Definition of uniformity

L_{max} : The measured maximum luminance of all measurement position.

L_{min} : The measured minimum luminance of all measurement position.

Note 7: Definition of Luminance :

Measure the luminance of white state at center point.

7 Environmental / Reliability Tests

No	Test Item	Condition	Remarks
1	High Temperature Operation	Ts= +70°C, 96hrs	IEC60068-2-1:2007 GB2423. 2-2008
2	Low Temperature Operation	Ta= -20°C, 96hrs	IEC60068-2-1:2007 GB2423.1-2008
3	High Temperature Storage	Ta= +80°C,96hrs	IEC60068-2-1:2007 GB2423. 2-2008
4	Low Temperature Storage	Ta= -30°C, 96hrs	IEC60068-2-1:2007 GB2423.1-2008
5	High Temperature & Humidity Operation	Ta= +60°C, 90% RH max,96 hours	IIEC60068-2-78:2001 GB/T2423.3-2006
6	Thermal Shock (Non-operation)	-30°C 30 min ~ +80°C 30 min Change time: 5min, 20 Cycle	Start with cold temperature, end with high temperature IEC60068-2-14:1984, GB2423.22-2002
7	ESD	C=150pF, R=330 Ω, 5 points/panel , Air:±8KV, 5 times Contact: ±4KV, 5 times (Environment: 15°C ~ 35°C, 30% ~ 60%, 86Kpa ~ 106Kpa)	IEC61000-4-2:2001 GB/T17626.2-2006
8	Vibration (Non-operation)	Frequency range: 10~55Hz, Stroke: 1.5mm , Sweep: 10Hz~55Hz~10Hz 2 hours for each direction of X .Y. Z. (6 hours for total)	IEC60068-2-6:1982 GB/T2423.10-1995
9	Mechanical Shock (Non-operation)	Half Sine Wave 60G ,6ms,±X,±Y,±Z 3times for each direction	IEC60068-2-27:1987 GB/T2423.5—1995
10	Package Drop Test	Height: 60 cm, 1 corner, 3 edges, 6 surfaces	IEC60068-2-32:1990 GB/T2423.8-1995



Notes:

1. The test result shall be evaluated after the sample has been left at room temperature and humidity for 2 hours without load. No condensation shall be accepted. The sample will not be accepted if appear these defects:
 - 1).Air bubble in the LCD;
 - 2).Seal leak
 - 3).Non-display
 - 4).missing segments
 - 5).Glass crack
 - 6).CR reduction >40%
 - 7).IDD increase >100%
 - 8).Brightness reduction >50%
 - 9).Color coordinate tolerance >0.05
2. ≤7.0 inch: The size of sample is 5pcs;
>7.0 inch: The size of sample is 2pcs;
3. One test sample must complete each test item;
- 4.In case of malfunction defect caused by ESD damage, if it would be recovered to normal state after resetting, it would be judge as a good part.
- 5.In the test of High Temperature Operation and High Temperature & Humidity Operation ,the operation temperature is the surface temperature of module.

8 Mechanical Drawing

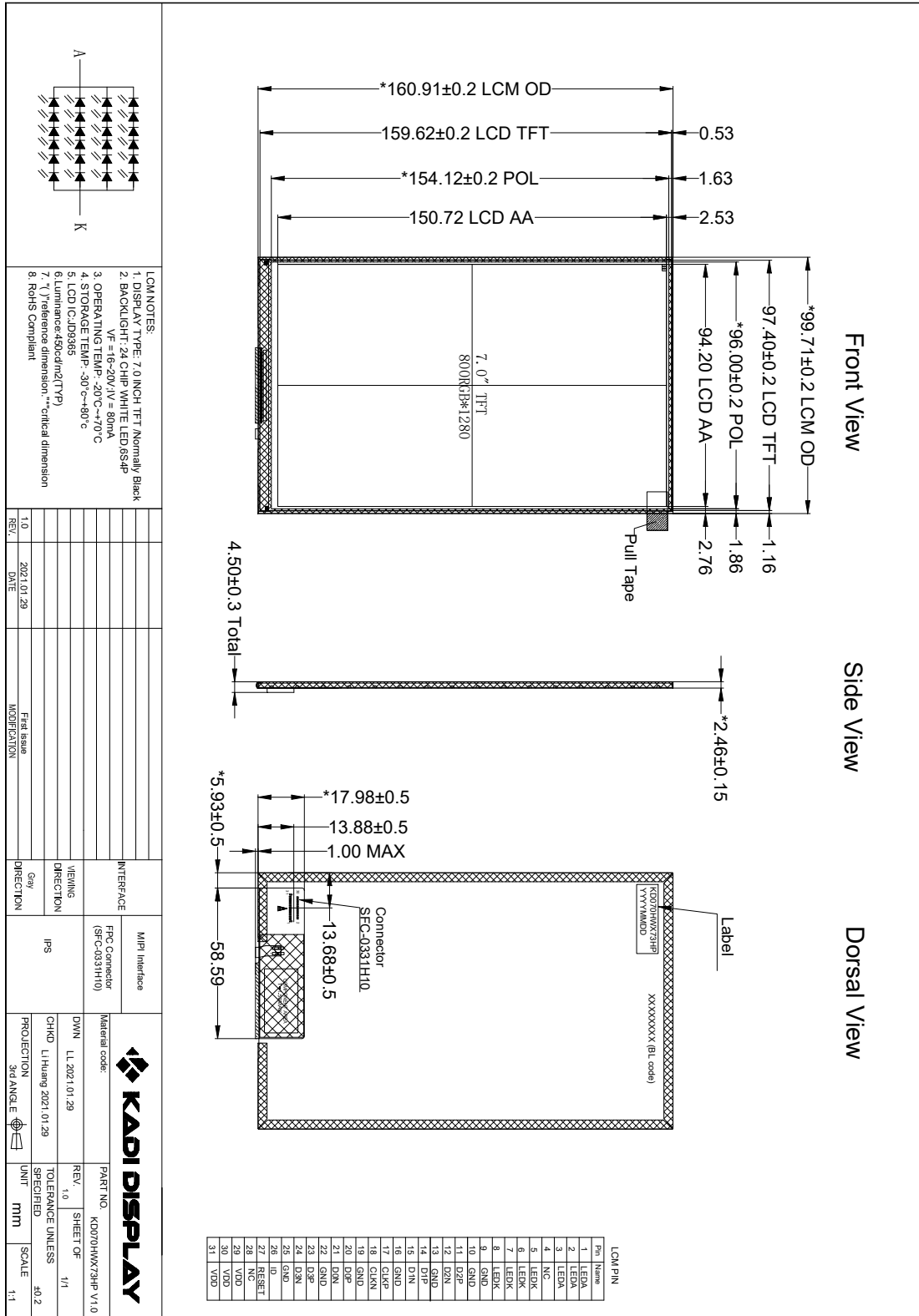

9 Packing

Packing Method

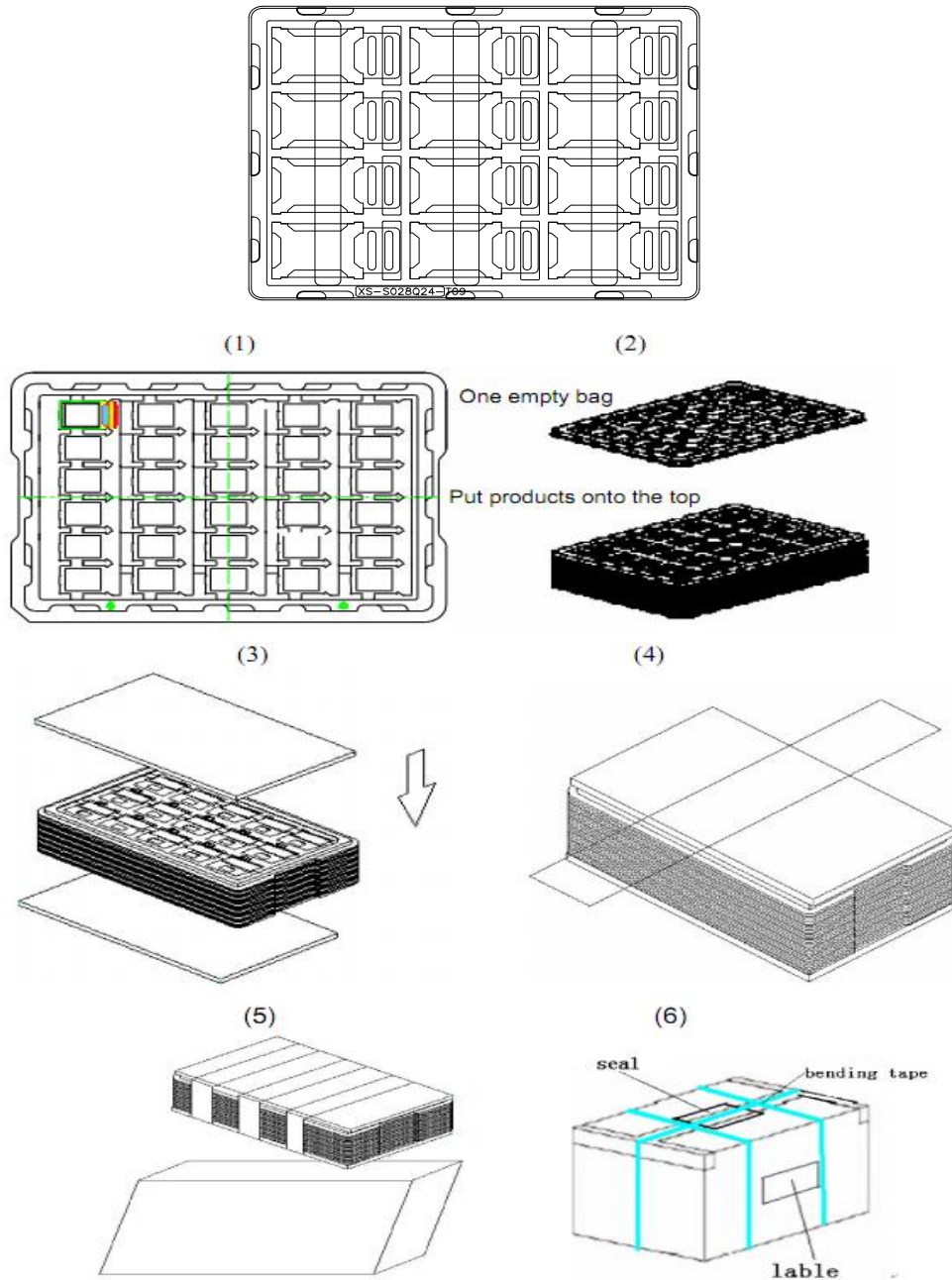

1. Put module into tray cavity:
2. Tray stacking
3. Put 1 cardboard under the tray stack and 1 cardboard above:
4. Fix the cardboard to the tray stack with adhesive tape:
5. Put the tray stack into carton.
6. Carton sealing with adhesive tape

10. Precautions for Use of LCD modules

10.1 Handling Precautions

10.1.1. The display panel is made of glass. Do not subject it to a mechanical shock by dropping it from a high place, etc.

10.1.2. If the display panel is damaged and the liquid crystal substance inside it leaks out, be sure not to get any in your mouth, if the substance comes into contact with your skin or clothes, promptly wash it off using soap and water.

10.1.3. Do not apply excessive force to the display surface or the adjoining areas since this may cause the color tone to vary.

10.1.4. The polarizer covering the display surface of the LCD module is soft and easily scratched. Handle this polarizer carefully.

10.1.5. If the display surface is contaminated, breathe on the surface and gently wipe it with a soft dry cloth. If still not completely clear, moisten cloth with one of the following solvents:

- Isopropyl alcohol
- Ethyl alcohol

Solvents other than those mentioned above may damage the polarizer. Especially, do not use the following:

- Water
- Ketene

10.1.6. Do not attempt to disassemble the LCD Module.

10.1.7. If the logic circuit power is off, do not apply the input signals.

10.1.8. To prevent destruction of the elements by static electricity, be careful to maintain an optimum work environment.

10.1.8.1. Be sure to ground the body when handling the LCD Modules.

10.1.8.2. Tools required for assembly, such as soldering irons, must be properly ground.

10.1.8.3. To reduce the amount of static electricity generated, do not conduct assembly and other work under dry conditions.

10.1.8.4. The LCD Module is coated with a film to protect the display surface. Be care when peeling off this protective film since static electricity may be generated.

10.2 Storage Precautions

10.2.1. When storing the LCD modules, avoid exposure to direct sunlight or to the light of fluorescent lamps.

10.2.2. The LCD modules should be stored under the storage temperature range. If the LCD modules will be stored for a long time, the recommend condition is:

Temperature : 0°C ~ 40°C Relatively humidity: ≤80%

10.2.3. The LCD modules should be stored in the room without acid, alkali and harmful gas.

10.3 Transportation Precautions

The LCD modules should be no falling and violent shocking during transportation, and also should avoid excessive press, water, damp and sunshine.